

Zero Duality Gap in Optimal Power Flow Problem

Javad Lavaei and Steven H. Low

Abstract—The optimal power flow (OPF) problem is nonconvex and generally hard to solve. In this paper, we propose a semidefinite programming (SDP) optimization, which is the dual of an equivalent form of the OPF problem. A global optimum solution to the OPF problem can be retrieved from a solution of this convex dual problem whenever the duality gap is zero. A necessary and sufficient condition is provided in this paper to guarantee the existence of no duality gap for the OPF problem. This condition is satisfied by the standard IEEE benchmark systems with 14, 30, 57, 118 and 300 buses as well as several randomly generated systems. Since this condition is hard to study, a sufficient zero-duality-gap condition is also derived. This sufficient condition holds for IEEE systems after small resistance (10^{-5} per unit) is added to every transformer that originally assumes zero resistance. We investigate this sufficient condition and justify that it holds widely in practice. The main underlying reason for the successful convexification of the OPF problem can be traced back to the modeling of transformers and transmission lines as well as the non-negativity of physical quantities such as resistance and inductance.

Index Terms—Power System, Optimal Power Flow, Convex Optimization, Linear Matrix Inequality, Polynomial-Time Algorithm.

I. INTRODUCTION

The optimal power flow (OPF) problem deals with finding an optimal operating point of a power system that minimizes an appropriate cost function such as generation cost or transmission loss subject to certain constraints on power and voltage variables [1]. Started by the work [2] in 1962, the OPF problem has been extensively studied in the literature and numerous algorithms have been proposed for solving this highly nonconvex problem [3], [4], [5], including linear programming, Newton Raphson, quadratic programming, nonlinear programming, Lagrange relaxation, interior point methods, artificial intelligence, artificial neural network, fuzzy logic, genetic algorithm, evolutionary programming and particle swarm optimization [1], [6], [7], [8]. A good number of these methods are based on the Karush-Kuhn-Tucker (KKT) necessary conditions, which can only guarantee a locally optimal solution, in light of the nonconvexity of the OPF problem [9]. This nonconvexity is partially due to the nonlinearity of physical parameters, namely active power, reactive power and voltage magnitude.

In the past decade, much attention has been paid to devising efficient algorithms with guaranteed performance for the OPF problem. For instance, the recent papers [10] and [11] propose nonlinear interior-point algorithms for an equivalent current injection model of the problem. An improved implementation of the automatic differentiation technique for the OPF problem

is studied in the recent work [12]. In an effort to convexify the OPF problem, it is shown in [13] that the load flow problem of a radial distribution system can be modeled as a convex optimization problem in the form of a conic program. Nonetheless, the results fail to hold for a meshed network, due to the presence of arctangent equality constraints [14]. Nonconvexity appears in more sophisticated power problems such as the stability constrained OPF problem where the stability at the operating point is an extra constraint [15], [16] or the dynamic OPF problem where the dynamics of the generators are also taken into account [17], [18]. The recent paper [19] proposes a convex relaxation to solve the OPF problem efficiently and tests its results on IEEE systems. Some of the results derived in the present work are related to this well-known convex relaxation. However, [19] drops a rank constraint in the original OPF without any justification in order to obtain a convex formulation.

As will be shown in this paper, the OPF problem is NP-hard in the worst case. Our recent work also proves that a closely related problem of finding an optimal operating point of a radiating antenna circuit is an NP-complete problem, by reducing the number partitioning problem to the antenna problem [20]. The goal of the present work is to exploit the physical properties of power systems and obtain a polynomial-time algorithm to find a global optimum of the OPF problem for a large class of power networks.

In this paper, we suggest solving the dual of an equivalent form of the OPF problem (referred to as the Dual OPF problem), rather than the OPF problem itself. This dual problem is a convex semidefinite program and therefore can be solved efficiently (in polynomial time). However, the optimal objective value of the dual problem is only a lower bound on the optimal value of the original OPF problem and the lower bound may not be tight (in presence of a nonzero duality gap) [21]. A globally optimal solution to the OPF problem can be recovered from a solution to the Dual OPF problem if the duality gap is zero (i.e. strongly duality holds between these two optimizations). In this paper, we derive a necessary and sufficient condition to guarantee zero duality gap. Interestingly, this condition is satisfied for all the five IEEE benchmark systems archived at [22] with 14, 30, 57, 118 and 300 buses, in addition to several randomly generated systems. In other words, these practical systems can all be convexified via the new formulation proposed here. In order to study why the duality gap is zero for the IEEE systems, we also derive a sufficient zero-duality-gap condition, which reveals many useful properties of power systems. This sufficient condition holds for IEEE systems after a small perturbation in a few entries of the admittance matrix, in order to make the graph corresponding to the resistive part of the power network strongly connected.

To study the sufficient zero-duality-gap condition provided

Javad Lavaei is with the Department of Control and Dynamical Systems, California Institute of Technology (email: lavaei@cds.caltech.edu).

Steven H. Low is with Computer Science and Electrical Engineering Departments, California Institute of Technology (email: slow@caltech.edu).

here, we first consider a resistive network with only resistive and constant-active-power loads. The OPF problem in this special case is also NP-hard. We exploit some physical properties of power circuits and prove that the duality gap is zero for a modified version of the OPF problem. Later on, we show that this modified OPF problem is expected to have the same solution as the OPF problem. The results are then extended to general networks with no constraints on reactive loads. It is shown that by fixing the real part of the admittance matrix Y , there is an unbounded region so that if the imaginary part of Y belongs to that region, the duality gap is zero. In other words, there is an unbounded set of network admittances for which the duality gap is zero for all possible values of loads and physical limits. The results are then extended to a general OPF problem. It is worth mentioning that we have proved in [35] that zero duality gap for the classical OPF problem studied here implies zero duality gap for a general OPF-based problem in which there could be more variables (such as transformer ratios and variable shunt elements) and more constraints (such as dynamic or contingency constraints). Hence, the results of this work make it possible to convexify several fundamental power problems that have been studied for about half a century.

The rest of the paper is organized as follows. The OPF problem is formulated in Section II. A polynomial-time algorithm is proposed in Section III to solve the OPF problem and two conditions are derived to guarantee a zero duality gap. These conditions are studied in Section IV. Various results are illustrated in Section V through IEEE benchmark systems and smaller examples. Concluding remarks are drawn in Section VI. Some background on semidefinite programming is provided in Appendix A and, finally, a few proofs are collected in Appendices B and C.

Notations: The following notations are used in this paper:

- i : The imaginary unit.
- \mathbf{R} : The set of real numbers.
- $\text{Re}\{\cdot\}$ and $\text{Im}\{\cdot\}$: The operators returning the real and imaginary parts of a complex matrix.
- $*$: The conjugate transpose operator.
- T : The transpose operator.
- \succeq and \preceq : The matrix inequality signs in the positive semidefinite sense (i.e. given two symmetric matrices A and B , $A \succeq B$ implies $A - B$ is a positive semidefinite matrix, meaning that its eigenvalues are all nonnegative).
- Tr : The matrix trace operator.
- $|\cdot|$: The absolute value operator.

II. OPF PROBLEM: FORMULATION AND COMPUTATIONAL COMPLEXITY

Consider a power network with the set of buses $\mathcal{N} := \{1, 2, \dots, n\}$, the set of generator buses $\mathcal{G} \subseteq \mathcal{N}$ and the set of flow lines $\mathcal{L} \subseteq \mathcal{N} \times \mathcal{N}$. Define the parameters of the system as follows:

- $P_{D_k} + Q_{D_k}i$: The given apparent power of the load connected to bus $k \in \mathcal{N}$ (this number is zero whenever bus k is not connected to any load).
- $P_{G_k} + Q_{G_k}i$: The apparent power of the generator connected to bus $k \in \mathcal{G}$.

- V_k : Complex voltage at bus $k \in \mathcal{N}$.
- P_{lm} : Active power transferred from bus $l \in \mathcal{N}$ to the rest of the network through line $(l, m) \in \mathcal{L}$.
- S_{lm} : Apparent power transferred from bus $l \in \mathcal{N}$ to the rest of the network through line $(l, m) \in \mathcal{L}$.
- $f_k(P_{G_k}) = c_{k2}P_{G_k}^2 + c_{k1}P_{G_k} + c_{k0}$: Quadratic cost function with given nonnegative coefficients accounting for the cost of active power generation at bus $k \in \mathcal{G}$.

Let \mathbf{V} , \mathbf{P}_g and \mathbf{Q}_g denote the unknown vectors $\{V_k\}_{k \in \mathcal{N}}$, $\{P_{G_k}\}_{k \in \mathcal{G}}$, and $\{Q_{G_k}\}_{k \in \mathcal{G}}$, respectively. The classical OPF problem aims to minimize $\sum_{k \in \mathcal{G}} f_k(P_{G_k})$ over the unknown parameters \mathbf{V} , \mathbf{P}_g and \mathbf{Q}_g subject to the power balance equations at all buses and the physical constraints

$$P_k^{\min} \leq P_{G_k} \leq P_k^{\max}, \quad \forall k \in \mathcal{G} \quad (1a)$$

$$Q_k^{\min} \leq Q_{G_k} \leq Q_k^{\max}, \quad \forall k \in \mathcal{G} \quad (1b)$$

$$V_k^{\min} \leq |V_k| \leq V_k^{\max}, \quad \forall k \in \mathcal{N} \quad (1c)$$

$$|S_{lm}| \leq S_{lm}^{\max}, \quad \forall (l, m) \in \mathcal{L} \quad (1d)$$

$$|P_{lm}| \leq P_{lm}^{\max}, \quad \forall (l, m) \in \mathcal{L} \quad (1e)$$

$$|V_l - V_m| \leq \Delta V_{lm}^{\max}, \quad \forall (l, m) \in \mathcal{L} \quad (1f)$$

where $P_k^{\min}, P_k^{\max}, Q_k^{\min}, Q_k^{\max}, V_k^{\min}, V_k^{\max}, S_{lm}^{\max}, P_{lm}^{\max}, \Delta V_{lm}^{\max}$ are some given real numbers such that $S_{lm}^{\max} = S_{ml}^{\max}$ and $P_{lm}^{\max} = P_{ml}^{\max}$. Note that some of the constraints stated in (1) may not be needed for a practical OPF problem, in which case the undesired constraints can be removed by setting the corresponding lower/upper bounds as infinity. For instance, the line flow constraints (1d) and (1e) might not be necessary simultaneously or the constraint (1f) could be redundant, depending on the situation. Although not stated explicitly, we assume throughout this work that the OPF problem is feasible and that $\mathbf{V} = 0$ does not satisfy its constraints.

Derive the circuit model of the power network by replacing every transmission line and transformer with their equivalent Π models [1]. In this circuit model, let y_{kl} denote the mutual admittance between buses k and l , and y_{kk} denote the admittance-to-ground at bus k , for every $k, l \in \mathcal{N}$ (note that $y_{kl} = 0$ if $(k, l) \notin \mathcal{L}$). Let Y represent the admittance matrix of this equivalent circuit model, which is an $n \times n$ complex-valued matrix whose (k, l) entry is equal to $-y_{kl}$ if $k \neq l$ and $y_{kk} + \sum_{m \in \mathcal{N}(k)} y_{km}$ otherwise, where $\mathcal{N}(k)$ denotes the set of all buses that are directly connected to bus k . Define the current vector $\mathbf{I} := [I_1 \ I_2 \ \dots \ I_n]^T$ as $Y\mathbf{V}$. Note that I_k represents the net current injected to bus $k \in \mathcal{N}$.

It is shown in Appendix B that the OPF problem is NP-hard, which implies that an arbitrary (general) OPF problem may not be solvable in polynomial time. However, the goal of this paper is to show that an OPF problem corresponding to a practical power network is structured in such a way that it might be solved efficiently in polynomial time even if it could have multiple local minima with a nonconvex (disconnected) feasibility region.

III. NEW APPROACH TO SOLVING OPF

By denoting the standard basis vectors in \mathbf{R}^n as e_1, e_2, \dots, e_n , let a number of matrices be defined now for

every $k \in \mathcal{N}$ and $(l, m) \in \mathcal{L}$:

$$\begin{aligned}
Y_k &:= e_k e_k^T Y, \\
Y_{lm} &:= (\bar{y}_{lm} + y_{lm}) e_l e_l^T - (y_{lm}) e_l e_m^T \\
\mathbf{Y}_k &:= \frac{1}{2} \begin{bmatrix} \text{Re}\{Y_k + Y_k^T\} & \text{Im}\{Y_k^T - Y_k\} \\ \text{Im}\{Y_k - Y_k^T\} & \text{Re}\{Y_k + Y_k^T\} \end{bmatrix} \\
\mathbf{Y}_{lm} &:= \frac{1}{2} \begin{bmatrix} \text{Re}\{Y_{lm} + Y_{lm}^T\} & \text{Im}\{Y_{lm}^T - Y_{lm}\} \\ \text{Im}\{Y_{lm} - Y_{lm}^T\} & \text{Re}\{Y_{lm} + Y_{lm}^T\} \end{bmatrix} \\
\bar{\mathbf{Y}}_k &:= \frac{-1}{2} \begin{bmatrix} \text{Im}\{Y_k + Y_k^T\} & \text{Re}\{Y_k - Y_k^T\} \\ \text{Re}\{Y_k^T - Y_k\} & \text{Im}\{Y_k + Y_k^T\} \end{bmatrix} \\
\bar{\mathbf{Y}}_{lm} &:= \frac{-1}{2} \begin{bmatrix} \text{Im}\{Y_{lm} + Y_{lm}^T\} & \text{Re}\{Y_{lm} - Y_{lm}^T\} \\ \text{Re}\{Y_{lm}^T - Y_{lm}\} & \text{Im}\{Y_{lm} + Y_{lm}^T\} \end{bmatrix} \\
M_k &:= \begin{bmatrix} e_k e_k^T & 0 \\ 0 & e_k e_k^T \end{bmatrix} \\
M_{lm} &:= \begin{bmatrix} (e_l - e_m)(e_l - e_m)^T & 0 \\ 0 & (e_l - e_m)(e_l - e_m)^T \end{bmatrix} \\
\mathbf{X} &:= \begin{bmatrix} \text{Re}\{\mathbf{V}\}^T & \text{Im}\{\mathbf{V}\}^T \end{bmatrix}^T
\end{aligned}$$

where \bar{y}_{lm} denotes the value of the shunt element at bus l associated with the Π model of the line (l, m) . For every $k \in \mathcal{N}$, define $P_{k,\text{inj}}$ and $Q_{k,\text{inj}}$ as the net active and reactive powers injected to bus k , i.e.,

$$\begin{aligned}
P_{k,\text{inj}} &:= P_{G_k} - P_{D_k}, & \forall k \in \mathcal{G} \\
Q_{k,\text{inj}} &:= Q_{G_k} - Q_{D_k}, & \forall k \in \mathcal{G} \\
P_{k,\text{inj}} &:= -P_{D_k}, & \forall k \in \mathcal{N} \setminus \mathcal{G} \\
Q_{k,\text{inj}} &:= -Q_{D_k}, & \forall k \in \mathcal{N} \setminus \mathcal{G}
\end{aligned}$$

Lemma 1: The following relations hold for every $k \in \mathcal{N}$ and $(l, m) \in \mathcal{L}$:

$$P_{k,\text{inj}} = \text{Tr}\{\mathbf{Y}_k \mathbf{X} \mathbf{X}^T\} \quad (2a)$$

$$Q_{k,\text{inj}} = \text{Tr}\{\bar{\mathbf{Y}}_k \mathbf{X} \mathbf{X}^T\} \quad (2b)$$

$$P_{lm} = \text{Tr}\{\mathbf{Y}_{lm} \mathbf{X} \mathbf{X}^T\} \quad (2c)$$

$$|S_{lm}|^2 = (\text{Tr}\{\mathbf{Y}_{lm} \mathbf{X} \mathbf{X}^T\})^2 + (\text{Tr}\{\bar{\mathbf{Y}}_{lm} \mathbf{X} \mathbf{X}^T\})^2 \quad (2d)$$

$$|V_k|^2 = \text{Tr}\{M_k \mathbf{X} \mathbf{X}^T\} \quad (2e)$$

$$|V_l - V_m|^2 = \text{Tr}\{M_{lm} \mathbf{X} \mathbf{X}^T\} \quad (2f)$$

Proof: See Appendix C.

Extend the definitions of $P_k^{\min}, P_k^{\max}, Q_k^{\min}, Q_k^{\max}$ from $k \in \mathcal{G}$ to every $k \in \mathcal{N}$, with $P_k^{\min} = P_k^{\max} = Q_k^{\min} = Q_k^{\max} = 0$ if $k \in \mathcal{N} \setminus \mathcal{G}$. Using Lemma 1, one can formulate the OPF problem in terms of \mathbf{X} as follows.

OPF problem formulated in \mathbf{X} : Minimize

$$\begin{aligned}
& \sum_{k \in \mathcal{G}} \left\{ c_{k2} (\text{Tr}\{\mathbf{Y}_k W\} + P_{D_k})^2 \right. \\
& \left. + c_{k1} (\text{Tr}\{\mathbf{Y}_k W\} + P_{D_k}) + c_{k0} \right\} \quad (3)
\end{aligned}$$

over the variables $\mathbf{X} \in \mathbf{R}^{2n}$ and $W \in \mathbf{R}^{2n \times 2n}$ subject to the following constraints for every $k \in \mathcal{N}$ and $(l, m) \in \mathcal{L}$

$$P_k^{\min} - P_{D_k} \leq \text{Tr}\{\mathbf{Y}_k W\} \leq P_k^{\max} - P_{D_k} \quad (4a)$$

$$Q_k^{\min} - Q_{D_k} \leq \text{Tr}\{\bar{\mathbf{Y}}_k W\} \leq Q_k^{\max} - Q_{D_k} \quad (4b)$$

$$(V_k^{\min})^2 \leq \text{Tr}\{M_k W\} \leq (V_k^{\max})^2 \quad (4c)$$

$$\text{Tr}\{\mathbf{Y}_{lm} W\}^2 + \text{Tr}\{\bar{\mathbf{Y}}_{lm} W\}^2 \leq (S_{lm}^{\max})^2 \quad (4d)$$

$$\text{Tr}\{\mathbf{Y}_{lm} W\} \leq P_{lm}^{\max} \quad (4e)$$

$$\text{Tr}\{M_{lm} W\} \leq (\Delta V_{lm}^{\max})^2 \quad (4f)$$

$$W = \mathbf{X} \mathbf{X}^T \quad (4g)$$

Note that the constraint $|P_{lm}| \leq P_{lm}^{\max}$ in the original OPF problem is changed to $P_{lm} \leq P_{lm}^{\max}$ in order to derive (4e). This modification can be done in light of the relations $P_{lm} + P_{ml} \geq 0$ and $P_{lm}^{\max} = P_{ml}^{\max}$. The above OPF formulation is not quadratic in \mathbf{X} , due to the objective function being of degree 4 with respect to the entries of \mathbf{X} as well as the constraint (4d). However, one can define some auxiliary variables to reformulate the OPF problem in a quadratic way with respect to X . To this end, Schur's complement formula yields that the constraint (4d) can be replaced by

$$\begin{bmatrix} -(S_{lm,\max})^2 & \text{Tr}\{\mathbf{Y}_{lm} W\} & \text{Tr}\{\bar{\mathbf{Y}}_{lm} W\} \\ \text{Tr}\{\mathbf{Y}_{lm} W\} & -1 & 0 \\ \text{Tr}\{\bar{\mathbf{Y}}_{lm} W\} & 0 & -1 \end{bmatrix} \preceq 0 \quad (5)$$

On the other hand, given a scalar α_k for some $k \in \mathcal{G}$, the constraint $f_k(P_{G_k}) \leq \alpha_k$ is equivalent to (by Schur's complement formula)

$$\begin{bmatrix} c_{k1} \text{Tr}\{\mathbf{Y}_k W\} - \alpha_k + a_k & \sqrt{c_{k2}} \text{Tr}\{\mathbf{Y}_k W\} + b_k \\ \sqrt{c_{k2}} \text{Tr}\{\mathbf{Y}_k W\} + b_k & -1 \end{bmatrix} \preceq 0 \quad (6)$$

where $a_k := c_{k0} + c_{k1} P_{D_k}$ and $b_k := \sqrt{c_{k2}} P_{D_k}$.

Using (5) and (6), one can reformulate the OPF problem formalized in (3) and (4) in a quadratic way. This leads to Optimization 1, which is equivalent to the OPF problem:

Optimization 1: Minimize $\sum_{k \in \mathcal{G}} \alpha_k$ over the scalar variables α_k 's and the matrix variables \mathbf{X} and W subject to the constraints (4a), (4b), (4c), (4e), (4f), (4g), (5) and (6).

The variable \mathbf{X} can be eliminated from Optimization 1 by using the fact that a given matrix W can be written as $\mathbf{X} \mathbf{X}^T$ for some (nonzero) vector \mathbf{X} if and only if W is both positive semidefinite and rank 1. Hence, Optimization 2 below is an equivalent form of Optimization 1 whose variables are only W and α_k 's for $k \in \mathcal{G}$.

Optimization 2: This optimization is obtained from Optimization 1 by replacing the constraint (4g), i.e. $W = \mathbf{X} \mathbf{X}^T$, with the new constraints $W \succeq 0$ and $\text{rank}\{W\} = 1$.

Notice that since Optimization 2 has a rank constraint, it is nonconvex. However, removing the constraint $\text{rank}\{W\} = 1$ from this optimization makes it a semidefinite program (SDP), which is a convex problem (see Appendix A for a brief overview of SDP). This gives rise to Optimization 3 presented below.

Optimization 3: This optimization is obtained from Optimization 2 by removing the rank constraint $\text{rank}\{W\} = 1$.

Optimization 3 is indeed an SDP relaxation of the OPF problem. Assume that this convex optimization problem has a

rank-one optimal solution W^{opt} . Then, there exists a vector \mathbf{X}^{opt} such that $W^{\text{opt}} = \mathbf{X}^{\text{opt}}(\mathbf{X}^{\text{opt}})^T$. In that case, \mathbf{X}^{opt} is a global optimum of the OPF problem. However, since the OPF problem is NP-hard in general, Optimization 3 does not always have a rank-one solution. We numerically solved this optimization problem for IEEE test systems with 14, 30, 57, 118 and 300 buses using SEDUMI and noticed that each solution W^{opt} obtained always has rank two. The next lemma explains the reason why this occurs for IEEE systems.

Lemma 2: If Optimization 3 has a rank-one solution, then it must have an infinite number of rank-two solutions.

Proof: See Appendix C.

Lemma 2 states that Optimization 3 might have a rank-one solution that cannot be directly identified by solving it numerically. However, using the method proposed later in this work, one can verify that Optimization 3 always has a rank-one solution for all aforementioned IEEE test systems. This implies that these power systems can be convexified by a convex relaxation technique. However, the focus of this paper will not be on Optimization 3 due to the following reasons:

- The number of scalar variables of Optimization 3 is quadratic with respect to n (in light of the non-sparse structure of the matrix variable W_c). Hence, solving this optimization problem might be expensive and time-consuming for large values of n .
- It is hard to analytically study Optimization 3 to determine when it has a rank-one solution.

In this paper, we consider the dual of Optimization 3. To this end, define the following dual variables for every $k \in \mathcal{N}$ and $(l, m) \in \mathcal{L}$:

- $\underline{\lambda}_k, \underline{\gamma}_k, \underline{\mu}_k$: Lagrange multipliers associated with the lower inequalities in (4a), (4b) and (4c), respectively.
- $\bar{\lambda}_k, \bar{\gamma}_k, \bar{\mu}_k$: Lagrange multipliers associated with the upper inequalities in (4a), (4b) and (4c), respectively.
- λ_{lm}, μ_{lm} : Lagrange multipliers associated with the inequalities (4e) and (4f), respectively.
- $r_{lm}^1, r_{lm}^2, \dots, r_{lm}^6$: The matrix

$$\begin{bmatrix} r_{lm}^1 & r_{lm}^2 & r_{lm}^3 \\ r_{lm}^2 & r_{lm}^4 & r_{lm}^5 \\ r_{lm}^3 & r_{lm}^5 & r_{lm}^6 \end{bmatrix}$$

is the Lagrange multiplier associated with the matrix inequality (5).

- r_k^1, r_k^2 : If $k \in \mathcal{G}$, the matrix

$$\begin{bmatrix} 1 & r_k^1 \\ r_k^1 & r_k^2 \end{bmatrix} \quad (7)$$

is the Lagrange multiplier associated with the matrix inequality (6).

Let x and r denote the sets of all multipliers introduced in (i-iii) and (iv-v), respectively. Define some aggregate multipliers for every $k \in \mathcal{N}$ as follows

$$\begin{aligned} \lambda_k &:= \begin{cases} -\underline{\lambda}_k + \bar{\lambda}_k + c_{k1} + 2\sqrt{c_{k2}}r_k^1 & \text{if } k \in \mathcal{G} \\ -\underline{\lambda}_k + \bar{\lambda}_k & \text{otherwise} \end{cases} \\ \gamma_k &:= -\underline{\gamma}_k + \bar{\gamma}_k \\ \mu_k &:= -\underline{\mu}_k + \bar{\mu}_k \end{aligned}$$

Furthermore, define the functions

$$\begin{aligned} h(x, r) &:= \sum_{k \in \mathcal{N}} \left\{ \underline{\lambda}_k P_k^{\min} - \bar{\lambda}_k P_k^{\max} + \lambda_k P_{D_k} + \underline{\gamma}_k Q_k^{\min} \right. \\ &\quad \left. - \bar{\gamma}_k Q_k^{\max} + \gamma_k Q_{D_k} + \underline{\mu}_k (V_k^{\min})^2 - \bar{\mu}_k (V_k^{\max})^2 \right\} \\ &\quad + \sum_{k \in \mathcal{G}} (c_{k0} - r_k^2) - \sum_{(l, m) \in \mathcal{L}} \left\{ \lambda_{lm} P_{lm}^{\max} \right. \\ &\quad \left. + \mu_{lm} (\Delta V_{lm}^{\max})^2 + (S_{lm}^{\max})^2 r_{lm}^1 + r_{lm}^4 + r_{lm}^6 \right\} \end{aligned}$$

and

$$\begin{aligned} A(x, r) &:= \sum_{k \in \mathcal{N}} \left\{ \lambda_k \mathbf{Y}_k + \gamma_k \bar{\mathbf{Y}}_k + \mu_k M_k \right\} \\ &\quad + \sum_{(l, m) \in \mathcal{L}} \left\{ (2r_{lm}^2 + \lambda_{lm}) \mathbf{Y}_{lm} + 2r_{lm}^3 \bar{\mathbf{Y}}_{lm} + \mu_{lm} M_{lm} \right\} \end{aligned}$$

We propose an optimization problem in the sequel, which plays a central role in solving the OPF problem.

Optimization 4 (Dual OPF): Maximize the linear function $h(x, r)$ over the vectors $x \geq 0$ and r subject to the linear matrix inequalities

$$A(x, r) \succeq 0 \quad (8a)$$

$$\begin{bmatrix} r_{lm}^1 & r_{lm}^2 & r_{lm}^3 \\ r_{lm}^2 & r_{lm}^4 & r_{lm}^5 \\ r_{lm}^3 & r_{lm}^5 & r_{lm}^6 \end{bmatrix} \succeq 0, \quad \forall (l, m) \in \mathcal{L} \quad (8b)$$

$$\begin{bmatrix} 1 & r_k^1 \\ r_k^1 & r_k^2 \end{bmatrix} \succeq 0, \quad \forall k \in \mathcal{G} \quad (8c)$$

The next theorem presents some important properties of Optimization 4.

Theorem 1: The following statements hold:

- Optimization 4 is the dual of the nonconvex problem of Optimization 1.
- Optimization 4 is the dual of Optimization 3 and strong duality holds between these optimizations. Moreover, the matrix variable W in Optimization 3 corresponds to a Lagrange multiplier for the inequality constraint $A(x, r) \succeq 0$ in Optimization 4.

Proof: See Appendix C.

The relationship among the OPF problem and Optimizations 1–4 are illustrated in Figure 1. This paper suggests solving Optimization 4, which is the dual of a reformulated OPF problem (i.e. Optimization 1) as well as the dual of a convex relaxation of the OPF problem (i.e. Optimization 3). Since Optimization 4 is an SDP, a globally optimization solution to this problem can be found in polynomial time. However, this solution can be used to retrieve a solution to the OPF problem only if the duality gap is zero for Optimization 1, meaning that the optimal objective values of Optimizations 1 and 4 are identical. The next theorem investigates this issue in more details.

Theorem 2: The following statements hold:

- The duality gap is zero for Optimization 1 if and only if the SDP Optimization 3 has a rank-one solution W^{opt} .

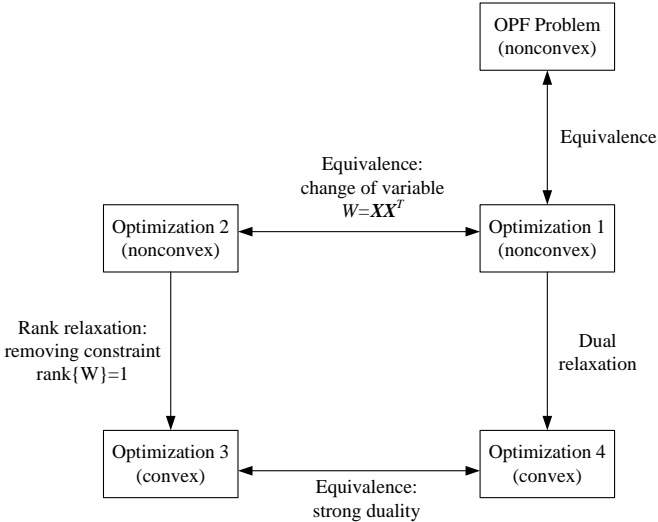

Fig. 1. The relationship among OPF and Optimizations 1–4.

- ii) The duality gap is zero for Optimization 1 if its dual (i.e. the SDP Optimization 4) has a solution $(x^{\text{opt}}, r^{\text{opt}})$ such that the positive semidefinite matrix $A(x^{\text{opt}}, r^{\text{opt}})$ has a zero eigenvalue of multiplicity 2.

Proof: See Appendix C.

Due to the reasons outlined right after Lemma 2, this paper mainly focuses on Condition (ii) (as opposed to Condition (i)), whose usefulness will become clear later. The next corollary explains how to recover a solution to the OPF problem whenever this zero-duality-gap condition is satisfied.

Corollary 1: If the zero-duality-gap condition (ii) given in Theorem 2 is satisfied, then the following properties hold:

- Given any nonzero vector $[X_1^T \ X_2^T]^T$ in the null space of $A(x^{\text{opt}}, r^{\text{opt}})$, there exist two real-valued scalars ζ_1 and ζ_2 such that $\mathbf{V}^{\text{opt}} = (\zeta_1 + \zeta_2\mathbf{i})(X_1 + X_2\mathbf{i})$ is a global optimum of the OPF problem.
- Given any arbitrary solution W^{opt} of Optimization 3, the rank of W^{opt} is at most 2. Moreover, if the matrix W^{opt} has rank 2, then the matrix $(\rho_1 + \rho_2)EE^T$ is a rank-one solution of Optimization 3, where ρ_1 and ρ_2 are the nonzero eigenvalues of W^{opt} and E is the unit eigenvector associated with ρ_1 .

Proof: See Appendix C.

This paper suggests the following strategy for finding a global optimum of the OPF problem.

Algorithm for Solving OPF:

- 1) Compute a solution $(x^{\text{opt}}, r^{\text{opt}})$ of Optimization 4, which is the dual of an equivalent form of the OPF problem.
- 2) If the optimal value $h(x^{\text{opt}}, r^{\text{opt}})$ is $+\infty$, then the OPF problem is infeasible.
- 3) Find the multiplicity of the zero eigenvalue of the matrix $A(x^{\text{opt}}, r^{\text{opt}})$ and denote it as ψ .
- 4) If ψ is greater than 2, it might not be possible to solve the OPF problem in polynomial time.
- 5) If ψ is less than or equal to 2, then use the method explained in Part (i) of Corollary 1 to find a globally optimal solution \mathbf{V}^{opt} .

The main complexity of the above algorithm can be traced back to its Step 1, which requires solving the Dual OPF problem. As mentioned earlier, this optimization is an SDP problem and therefore can be solved in polynomial time. We tested our algorithm on several randomly generated power systems with all types of constraints given in (1) and observed that this algorithm found a global optimum of the OPF problem for all trials. Then, we considered the IEEE test systems with 14, 30, 57, 118 and 300 buses, whose physical constraints are in the form of (1a)-(1d), and made the following observations:

- Optimization 3 always leads to a rank-two solution, from which a rank-one solution can be found using the technique delineated in Part (ii) of Corollary 1. Hence, Part (i) of Theorem 2 yields that the duality gap is zero for all these IEEE systems.
- Our algorithm based on the Dual OPF works after a small perturbation of the matrix Y . More precisely, if a small resistance (10^{-5}) is added to each transformer that originally has zero resistance, the graph induced by the matrix $\text{Re}\{Y\}$ will become connected for each aforementioned IEEE system. This perturbation makes ψ equal to 2.

Before studying why the OPF problem associated with a real power system is expected to be solvable using the algorithm proposed earlier, we make several important remarks below.

Remark 1: The last step of our algorithm relies on Part (i) of Corollary 1, which states that there exist two real-valued scalars ζ_1 and ζ_2 such that $\mathbf{V}^{\text{opt}} = (\zeta_1 + \zeta_2\mathbf{i})(X_1 + X_2\mathbf{i})$. In order to find ζ_1 and ζ_2 , two (linear) equations are required. The voltage angle at the swing bus being zero introduces one such equation. The second one can be formed by identifying the active voltage constraints. Indeed, if $\underline{\mu}_k^{\text{opt}}$ (respectively, $\bar{\mu}_k^{\text{opt}}$) turns out to be nonzero for some $k \in \mathcal{N}$, then the relation $|V_k^{\text{opt}}| = V_k^{\text{min}}$ (respectively, $|V_k^{\text{opt}}| = V_k^{\text{max}}$) must hold.

Remark 2: Optimization 4 has two interesting properties for a practical power system. First, since most of the constraints specified in (1) are likely to be inactive, the vectors x^{opt} and r^{opt} are sparse. Moreover, the number of variables of Optimization 4 is $O(|\mathcal{L}|) + O(|\mathcal{N}|)$, which is expected to be equal to $O(|\mathcal{N}|)$ due to the very sparse topology of real power systems. Note that solving Optimization 4 for very large-scale power networks might be too costly, in which case it is recommended to use some sub-gradient techniques [19], [27].

Remark 3: Optimization 4 has the interesting property that the given loads together with the physical limits on voltage and power parameters only appear in the objective function, whereas the network topology (the matrix Y) shows up in its linear matrix constraints. Therefore, there is a natural decomposition between the load profile and the network topology in Optimization 4. This useful property, besides the linearity of Optimization 4, makes it possible to solve many more sophisticated problems efficiently, such as the OPF problem with stochastic and time-varying loads, and optimal network reconfiguration for minimizing power loss.

Remark 4: Most of the algorithms proposed in the past decade to solve the OPF problem are built on the KKT conditions written for the original or a reformulated OPF

problem. We highlight the differences between the Dual OPF and the KKT conditions:

- The duality gap could be zero for an OPF problem whose feasibility region has several disjoint components (see Case 1 in Appendix B). Hence, the OPF problem may have many local solutions, all of which satisfy the KKT conditions. In contrast, a global optimum of the OPF problem can be recovered by solving the Dual OPF when the duality gap is zero.
- The KKT conditions are based on both primal and dual variables (say \mathbf{X}, x, r), whereas the Dual OPF depends only on the dual variables (say x, r).
- There is a constraint $A(x, r) \succeq 0$ in the Dual OPF, and besides an optimal solution to the OPF problem satisfies the relation $A(x^{\text{opt}}, r^{\text{opt}})\mathbf{X}^{\text{opt}} = 0$. The constraint $A(x^{\text{opt}}, r^{\text{opt}})\mathbf{X}^{\text{opt}} = 0$ is part of the KKT conditions, implying that the matrix $A(x, r)$ should lose rank at optimality. However, the stronger constraint $A(x, r) \succeq 0$ is missing in the KKT conditions.

Indeed, it can be shown that if the constraint $A(x, r) \succeq 0$ is incorporated into the KKT conditions, then the resulting conditions are able to find a global optimum of the OPF problem when the duality gap is zero.

IV. ZERO DUALITY GAP FOR POWER SYSTEMS

In this section, we study the zero-duality-gap condition (ii) given in Theorem 2 in more details to justify why this condition is expected to hold widely in practice. To this end, we first study the OPF problem for DC networks, which is indeed an NP-hard problem. This helps find the useful properties of the Dual OPF problem, which will later be used to explore the solvability of the OPF problem for AC networks.

A. Resistive Networks with Active Loads

As can be seen in Case (ii) of Appendix B, the OPF problem is NP-hard even if the network is resistive and there are no reactive loads. This situation, which corresponds to DC power distribution, is itself important because (i) the active power loss in a power system is due to the resistive part of the network, and (ii) the study of this case reveals important facts about the general OPF problem. In this section, we prove zero duality gap for DC networks under a mild assumption, which is expected to hold in reality.

Throughout this part, assume that the power system is a resistive network (i.e. $\text{Im}\{Y\} = 0$) and that all loads are modeled as constant active powers. In the formulation of the OPF problem, it was assumed that the (active) power to be delivered to the load of bus $k \in \mathcal{N}$ must be exactly equal to P_{D_k} (this showed up in the power balance equations). Let the OPF problem be changed to allow delivering any power more than P_{D_k} to the load of bus k . To this end, define P_{L_k} as the power delivered to the load of bus k and P_{D_k} as the desired power requested by the load of bus k . In the OPF problem, we have the constraints

$$P_{L_k} = P_{D_k}, \quad \forall k \in \mathcal{N} \quad (9)$$

in the power balance equations. Modify the OPF problem by replacing the above constraints with the following

$$P_{L_k} \geq P_{D_k}, \quad \forall k \in \mathcal{N} \quad (10)$$

and name the resulting problem as *modified OPF problem*. Note that this variant of the OPF problem allows for the over-satisfaction of the loads. This idea has already been considered by some other papers too (see [34] and the references given therein). In what follows, we first study the modified OPF problem, and then explain why the OPF and modified OPF problems are expected to have the same solution.

Theorem 3: The duality gap is zero for the modified OPF problem.

Proof: One can draw a digram similar to the one depicted in Figure 1 for the modified OPF problem to obtain four optimization problems named modified Optimizations 1–4 (note that the name “modified Dual OPF” will be used for the modified Optimization 4). Now, it can be shown that the modified Dual OPF problem is the same as Optimization 4 with the exception of having the extra constraints

$$\lambda_k \geq 0, \quad \forall k \in \mathcal{N} \quad (11)$$

Let $(x^{\text{opt}}, r^{\text{opt}})$ denote a solution to the modified Dual OPF problem. The goal is to show that the multiplicity of the zero eigenvalue of $A(x^{\text{opt}}, r^{\text{opt}})$ is at most two. To this end, notice that the constraints (1b) and (1d) can be ignored due to the absence of reactive powers in the network (note that $S_{lk} = P_{lk}$ in this case). As a result,

$$\begin{aligned} \gamma_k &= 0, & \forall k \in \mathcal{N} \\ r_{lm}^1 &= \dots = r_{lm}^6 = 0, & \forall (l, m) \in \mathcal{L} \end{aligned}$$

Hence, the matrix $A(x^{\text{opt}}, r^{\text{opt}})$ can be expressed as

$$A(x^{\text{opt}}, r^{\text{opt}}) = \begin{bmatrix} T(x^{\text{opt}}, r^{\text{opt}}) & 0 \\ 0 & T(x^{\text{opt}}, r^{\text{opt}}) \end{bmatrix} \quad (12)$$

for some matrix $T(x^{\text{opt}}, r^{\text{opt}}) \in \mathcal{R}^{n \times n}$, where the (l, m) off-diagonal entry of $T(x^{\text{opt}}, r^{\text{opt}})$ is equal to

$$T_{lm}(x^{\text{opt}}, r^{\text{opt}}) = -\frac{y_{lm}}{2} (\lambda_{lm}^{\text{opt}} + \lambda_{ml}^{\text{opt}} + \lambda_l^{\text{opt}} + \lambda_m^{\text{opt}}) - \mu_{lm}^{\text{opt}} - \mu_{ml}^{\text{opt}}$$

if $(l, m) \in \mathcal{L}$ and is zero otherwise. On the other hand, since resistance is a nonnegative physical quantity, it can be shown that y_{lm} coming from the Π model of a transmission line or a transformer is always nonnegative. It follows from this fact together with the inequalities (11) and $x^{\text{opt}} \geq 0$ that all off-diagonal entries of the matrix $T(x^{\text{opt}}, r^{\text{opt}})$ are non-positive.

Assume for now that the graph of the power system is strongly connected, meaning that there exists a path between every two buses of the network [32]. Assume also that the nonnegative vector $(\lambda_1^{\text{opt}}, \dots, \lambda_n^{\text{opt}})$ is strictly positive. These assumptions imply that the matrix $T(x^{\text{opt}}, r^{\text{opt}})$ is irreducible and its off-diagonal entries are non-positive. Hence, the Perron-Frobenius theorem yields that the smallest eigenvalue of $T(x^{\text{opt}}, r^{\text{opt}})$ is simple, and as a result of (12), the smallest eigenvalue of $A(x^{\text{opt}}, r^{\text{opt}})$ is repeated twice [32]. Since this matrix is positive semidefinite, this simply implies that the multiplicity of the zero eigenvalue of $A(x^{\text{opt}}, r^{\text{opt}})$ is at most

2. Thus, the duality gap is zero for the modified OPF problem, by virtue of Part (ii) of Theorem 2.

Now, suppose that the power network is strongly connected, but the nonnegative vector $(\lambda_1^{\text{opt}}, \dots, \lambda_n^{\text{opt}})$ is not strictly positive. Perturb the constraint (11) as

$$\lambda_k \geq \varepsilon, \quad \forall k \in \mathcal{N}$$

for a small strictly positive number ε . Based on the above discussion, the duality gap is zero for the perturbed modified OPF problem and hence the perturbed modified Optimization 3 has a rank one solution, denoted by $W_\varepsilon^{\text{opt}}$ (see Part (i) of Theorem 2). Since $W_\varepsilon^{\text{opt}}$ has a bounded norm (due to the voltage constraints in the OPF problem), this matrix converges to a rank-one solution if ε tends to zero. Hence, the modified Optimization 3 has a rank-one solution for $\varepsilon = 0$ and therefore it follows from a variant of Condition (i) given in Theorem 2 that the duality gap is zero for the modified OPF problem. So far, it was assumed that the graph of the power system is connected. If not, it means that the OPF problem can be broken down into a number of decoupled OPF problems, each associated with a connected power sub-network. The proof is completed by repeating the aforementioned argument for each small-sized OPF problem. ■

Theorem 3 states that the duality gap becomes zero for the OPF problem if the load constraints are changed from equality to inequality, meaning that the over-satisfaction of the loads is permitted. It is important to study under what conditions the OPF and modified OPF problems have the same solution. This is addressed in the sequel in terms of the duals of these problems.

Lemma 3: The duals of the OPF problem and the modified OPF problem have the same solution if the vector $(\lambda_1^{\text{opt}}, \dots, \lambda_n^{\text{opt}})$ associated with the original (rather than the modified) OPF problem is nonnegative.

Proof: As stated in the proof of Theorem 3, the dual of the modified OPF problem is the same as the dual of the OPF problem but with the additional constraints $\lambda_1, \dots, \lambda_n \geq 0$. Therefore, if the optimal solution of the dual of the OPF problem satisfies these constraints, it means that the duals of the OPF and modified OPF problems have an identical solution. This completes the proof. ■

The following result can be easily derived from Lemma 3 and the proof of Theorem 3.

Corollary 2: The duality gap is zero for the OPF problem if $(\lambda_1^{\text{opt}}, \dots, \lambda_n^{\text{opt}})$ is positive. Moreover, the sufficient zero-duality-gap condition given in Part (ii) of Theorem 2 holds for the OPF problem if the vector $(\lambda_1^{\text{opt}}, \dots, \lambda_n^{\text{opt}})$ is strictly positive and the graph of the power network is strongly connected.

Remark 5: It might happen that the vector $(\lambda_1^{\text{opt}}, \dots, \lambda_n^{\text{opt}})$ is not positive, while the duality gap is still zero. To account for such cases, one can repeat the argument made above to obtain a less conservative condition for having a zero duality gap, which is the positivity of $\lambda_{lm}^{\text{opt}} + \lambda_{ml}^{\text{opt}} + \lambda_l^{\text{opt}} + \lambda_m^{\text{opt}}$ for every $(l, m) \in \mathcal{L}$.

Assume that the OPF and modified OPF problems have the same solution. Then, the duality gap is zero for the OPF problem, implying that Optimization 3 can solve the OPF problem exactly. However, in order for the algorithm proposed

here based on Optimization 4 to solve the OPF problem, two conditions must hold. The first one is the connectivity of the power network that holds in reality. The second one requires that every nonnegative aggregate multiplier λ_k^{opt} , $k \in \mathcal{N}$, be strictly positive. This condition holds for a generic OPF problem because λ_k^{opt} being zero implies that the load constraint $P_{L_k} = P_{D_k}$ can be removed from the OPF problem without changing the solution, which signifies that the given value P_{D_k} is not important at all.

A practical power system is often maintained at a normal condition, where if a load bus requests to receive a certain amount of active power or more, the optimal strategy is to deliver exactly the *minimum* amount of power requested. This normal operation results from the fact that generated power is not supposed to be sold at a negative price (note that λ_k^{opt} in practice plays the role of nodal price for the load of bus $k \in \mathcal{N}$). However, an abnormal operation may occur if the physical limits in the OPF problem are so tight that the OPF problem is over-constrained. Under this circumstance, it is possible that the OPF and modified OPF problems achieve different solutions. The next theorem shows that this cannot occur if some of the constraints are removed from the OPF problem to avoid making it over-constrained by choosing inappropriate physical limits.

Theorem 4: Consider a non-generator bus $k \in \mathcal{N} \setminus \mathcal{G}$. If the voltage constraints (1c) and (1f) associated with bus k and the flow constraint (1e) associated with every line connected to this bus are removed from the OPF problem, then λ_k^{opt} corresponding to this simplified OPF problem is nonnegative.

Proof: The (k, k) entry of $A(x^{\text{opt}}, r^{\text{opt}})$, under the assumptions made in the theorem, can be written as

$$\lambda_k^{\text{opt}} \left(y_{kk} + \sum_{l \in \mathcal{N}(k)} y_{kl} \right) \quad (13)$$

The proof follows from the following facts:

- The expression given in (13) must be nonnegative due to the positive semi-definiteness of $A(x^{\text{opt}}, r^{\text{opt}})$.
- Although y_{kk} might be negative, the overall term $y_{kk} + \sum_{l \in \mathcal{N}(k)} y_{kl}$ is always nonnegative (note that this term corresponds to the (k, k) entry of Y , which is the admittance of a passive network). ■

Consider a non-generator bus k . Since the load is known at this bus, extra constraints related to this bus can make the OPF problem infeasible or over-constrained if the limits are not defined properly. Note that the result of Theorem 4 can be easily generalized to generator buses as well. Hence, the multiplier λ_k^{opt} is expected to be nonnegative, something which is needed in Corollary 2 to guarantee the existence of no duality gap for the OPF problem.

In summary, in order to be able to solve the OPF problem in polynomial time, it suffices to have either of the following properties:

- The over-satisfaction of a load is allowed and therefore the modified OPF problem can be solved instead.
- The physical limits of the OPF problem are not chosen in such a way that the power system operates in an abnormal

condition, where the active power is offered to a load at a negative price.

Note that if neither of the above properties is satisfied, the duality gap can still be zero due to the condition proposed in Remark 5.

B. General Networks with No Reactive-Load Constraints

As before, consider the modified OPF problem obtained by: (i) replacing the equality constraint (9) with the inequality constraint (10), and (ii) ignoring the apparent line flow limits and taking only the active line flow limits into account. Assume that the matrix Y is complex, but any arbitrary (positive/negative) amount of reactive power can be injected to each bus $k \in \mathcal{N}$. In this case, the constraints (1b) can be ignored. On the other hand, one can write the matrix $A(x^{\text{opt}}, r^{\text{opt}})$ as

$$A(x^{\text{opt}}, r^{\text{opt}}) = \begin{bmatrix} T(x^{\text{opt}}, r^{\text{opt}}) & \bar{T}(x^{\text{opt}}, r^{\text{opt}}) \\ -\bar{T}(x^{\text{opt}}, r^{\text{opt}}) & T(x^{\text{opt}}, r^{\text{opt}}) \end{bmatrix} \quad (14)$$

for some real matrices $T(x^{\text{opt}}, r^{\text{opt}}), \bar{T}(x^{\text{opt}}, r^{\text{opt}}) \in \mathbf{R}^{n \times n}$. It can be concluded from the above relation and (12) that the matrix $\bar{T}(x^{\text{opt}}, r^{\text{opt}})$ becomes nonzero in the transition from resistive to general networks. Unlike the symmetric matrix $T(x^{\text{opt}}, r^{\text{opt}})$, the matrix $\bar{T}(x^{\text{opt}}, r^{\text{opt}})$ is skew-symmetric and therefore it cannot have only positive entries. This is an impediment to exploiting the Perron-Frobenius theorem. In what follows, we build on Theorem 3 to bypass this issue.

Given a small number $\varepsilon > 0$, consider the Dual OPF problem (Optimization 4) subject to the extra constraints

$$\|x\| \leq \frac{1}{\varepsilon}, \quad \|r\| \leq \frac{1}{\varepsilon}, \quad \varepsilon \leq \lambda_k \leq \frac{1}{\varepsilon}, \quad \forall k \in \mathcal{N} \quad (15)$$

where $\|\cdot\|$ is a vector norm. This optimization corresponds to the dual of a perturbed version of the modified OPF problem, which is referred to as ε -modified OPF problem in this paper. Note that when ε goes to zero, the solution of this problem approaches that of the original modified OPF problem. To derive the next theorem, with no loss of generality, assume that the resistive part of the power network is strongly connected.

Theorem 5: Given $\varepsilon > 0$, consider an arbitrary matrix $G \in \mathbf{R}^{n \times n}$, which satisfies all necessary properties for being the real part of the admittance matrix of a power network. There exists an unbound open set \mathcal{T}_G in $\mathbf{R}^{n \times n}$ such that for every $\bar{G} \in \mathcal{T}_G$, the duality gap is zero for the ε -modified OPF problem with $Y = G + \bar{G}i$, regardless of the specific values of the loads and limits in the constraints (1).

Proof: Write Y as $G + \bar{G}i$, where G is a known matrix and \bar{G} is a matrix variable. Now, the matrix $A(x, r)$ depends on the variable \bar{G} , in addition to x and r . To account for this dependence explicitly, we use the notation $A(x, r, \bar{G})$ instead of $A(x, r)$. Let \mathcal{C} denote the set of all triple (x, r, \bar{G}) such that

- i) $A(x, r, \bar{G})$ as well as the matrices given in (8b) and (8c) are all positive semidefinite.
- ii) The dimension of the null space of $A(x, r, \bar{G})$ is at least 3.
- iii) The relations $x \geq 0$ and (15) are satisfied.

The way \mathcal{C} is defined makes it a closed semi-algebraic set (note that the set \mathcal{C} can be described by a number of polynomial

inequalities). Recall that \mathcal{C} belongs to the space associated with the variable (x, r, \bar{G}) . Project this set on the subspace corresponding to its variable \bar{G} and denote the resulting subset as \mathcal{C}_G . Define \mathcal{T}_G as the complement of \mathcal{C}_G . Note that \mathcal{T}_G contains every matrix \bar{G} for which there does not exist a vector (x, r) such that Conditions (i–iii) given above are all satisfied. One can observe that the sufficient zero-duality-gap condition given in Theorem 2 is satisfied for the ε -modified OPF problem with $Y = G + \bar{G}i$ as long as $\bar{G} \in \mathcal{T}_G$. The proof of this theorem follows from the facts given below:

- Since \mathcal{C} is closed and bounded (due to the relations given in (15)), the projection set \mathcal{C}_G is closed as well. Therefore, the complement of \mathcal{C}_G , i.e. \mathcal{T}_G , is an open set.
- Consider a diagonal matrix \bar{G} . It can be verified that the matrix $\bar{T}(x, r, \bar{G})$ is zero in this case. Thus, the matrix $A(x, r, \bar{G})$ has the block-diagonal structure (12), meaning that the non-resistive part of the network has disappeared. Hence, it can be inferred from the proof of Theorem 3 that the duality gap is zero in this case. As a result, \bar{G} must belong to \mathcal{T}_G .
- The set of diagonal matrices is unbounded. ■

As done in the preceding subsection, the OPF and modified OPF problems are expected to have the same solution; otherwise the power system may not work in a normal condition. Note that the condition provided in Theorem 4 to guarantee the same solution for the OPF and modified OPF problems still holds for a general network with no constraints on reactive loads. In this subsection, we perturbed the modified OPF problem and defined an ε -modified OPF problem. Theorem 5 states that for every $\text{Re}\{Y\}$ (that could be arbitrarily large or small), there exists an open, unbounded region for $\text{Im}\{Y\}$ such that the algorithm proposed in this paper can find a global optimum of the ε -modified OPF problem with $Y = \text{Re}\{Y\} + \text{Im}\{Y\}i$ in polynomial time. The importance of this result is as follows: *when the duality gap is zero for a topology Y , then the ε -modified OPF problem corresponding to every possible load profiles and physical limits can be convexified.*

C. General Networks

In this part, we combine the ideas presented in the last two subsections to study the OPF problem associated with a general network. For simplicity in the presentation, remove the constraints $|S_{lm}| \leq S_{lm}^{\text{max}}$ (where $(l, m) \in \mathcal{L}$), because of its similarity to the constraint $|P_{lm}| \leq P_{lm}^{\text{max}}$. Consider the matrix $A(x^{\text{opt}}, r^{\text{opt}})$, which can be expressed as

$$A(x^{\text{opt}}, r^{\text{opt}}) = \begin{bmatrix} T(x^{\text{opt}}, r^{\text{opt}}) & \bar{T}(x^{\text{opt}}, r^{\text{opt}}) \\ -\bar{T}(x^{\text{opt}}, r^{\text{opt}}) & T(x^{\text{opt}}, r^{\text{opt}}) \end{bmatrix}$$

where $T(x^{\text{opt}}, r^{\text{opt}})$ is symmetric and $\bar{T}(x^{\text{opt}}, r^{\text{opt}})$ is skew-symmetric. As observed in both the resistive case and the general case with no reactive-load constraints, the duality gap can be pushed towards zero if the off-diagonal entries of $T(x^{\text{opt}}, r^{\text{opt}})$ are all non-positive. In what follows, we first study the sign structure of $T(x^{\text{opt}}, r^{\text{opt}})$.

As carried out in Subsection IV-A, define $P_{D_k} + Q_{D_k}i$ as the apparent power requested by load $k \in \mathcal{N}$ and $P_{L_k} + Q_{L_k}i$

as the apparent power delivered to load $k \in \mathcal{N}$. In the original OPF problem, the equalities

$$P_{L_k} = P_{D_k}, \quad Q_{L_k} = Q_{D_k}, \quad \forall k \in \mathcal{N} \quad (16)$$

must hold. If these equalities are replaced by the inequalities

$$P_{L_k} \geq P_{D_k}, \quad Q_{L_k} \geq Q_{D_k}, \quad \forall k \in \mathcal{N} \quad (17)$$

then the optimal solutions λ_k^{opt} and γ_k^{opt} corresponding to the dual of the modified OPF problem will both become nonnegative. On the other hand, the $(k, l) \in \mathcal{L}$ entry of $T(x^{\text{opt}}, r^{\text{opt}})$ can be obtained as

$$T_{kl}(x^{\text{opt}}, r^{\text{opt}}) = -\frac{\text{Re}\{y_{kl}\}}{2} (\lambda_{kl}^{\text{opt}} + \lambda_{kl}^{\text{opt}} + \lambda_k^{\text{opt}} + \lambda_l^{\text{opt}}) + \frac{\text{Im}\{y_{kl}\}}{2} (\gamma_k^{\text{opt}} + \gamma_l^{\text{opt}}) - \mu_{kl}^{\text{opt}} - \mu_{kl}^{\text{opt}} \quad (18)$$

With no loss of generality, assume that there exists no phase shifting transformer in the power system (for the analysis presented next, one may need to replace every phase shifting transformer with the model proposed in [35]). Due to the particular models of transmission lines and transformers as well as the non-negativity of resistance and capacitance, the matrix Y has the following two properties:

- P1) The off-diagonal entries of the real part of Y are non-positive.
- P2) The off-diagonal entries of the imaginary part of Y are nonnegative.

It follows from these properties and the relation (18) that the off-diagonal entries of $T(x^{\text{opt}}, r^{\text{opt}})$ are non-positive if $\lambda_k^{\text{opt}}, \gamma_k^{\text{opt}} \geq 0, \forall k \in \mathcal{N}$, or equivalently if the equality load constraints (16) are replaced by the inequality load constraints (17). Unlike $\lambda_1^{\text{opt}}, \dots, \lambda_n^{\text{opt}}$ that are expected to be all nonnegative, a few of $\gamma_1^{\text{opt}}, \dots, \gamma_n^{\text{opt}}$ might become negative. Indeed, it is known that the injection of a negative reactive power to a bus might reduce the optimal generation cost, especially when there exists a large capacitor bank at the same bus.

Hence, the sufficient condition $\lambda_k^{\text{opt}}, \gamma_k^{\text{opt}} \geq 0, \forall k \in \mathcal{N}$, for guaranteeing a nice sign structure on $T(x^{\text{opt}}, r^{\text{opt}})$ does not always hold. Now, we wish to study a less conservative sufficient condition here. It follows from (18) that the off-diagonal entries of $T(x^{\text{opt}}, r^{\text{opt}})$ are non-positive if

$$\frac{\text{Re}\{y_{kl}\}}{2} (\lambda_{kl}^{\text{opt}} + \lambda_{kl}^{\text{opt}} + \lambda_k^{\text{opt}} + \lambda_l^{\text{opt}}) - \frac{\text{Im}\{y_{kl}\}}{2} (\gamma_k^{\text{opt}} + \gamma_l^{\text{opt}}) \geq 0 \quad (19)$$

for every $(k, l) \in \mathcal{L}$. This condition is satisfied for IEEE benchmark systems. The interpretation of this condition for a single line $(k, l) \in \mathcal{L}$ is as follows:

- Define a modified OPF with the following active/reactive load constraints

$$P_{L_m} = P_{D_m}, \quad Q_{L_m} = Q_{D_m}, \quad \forall m \in \mathcal{N} \setminus \{k, l\} \\ P_{L_m} \geq P_{D_m}, \quad Q_{L_m} \geq Q_{D_m}, \quad \forall m \in \{k, l\}$$

where the load over-satisfaction at buses k and l must obey the relations

$$P_{L_k} - P_{D_k} = P_{L_l} - P_{D_l} = \tau \times \text{Re}\{y_{kl}\} \\ Q_{L_k} - Q_{D_k} = Q_{L_l} - Q_{D_l} = \tau \times \text{Im}\{-y_{kl}\} \\ \max\{P_{l_m}, P_{m_l}\} \leq P_{l_m}^{\text{max}} - \tau \times \text{Re}\{y_{kl}\}$$

for some nonnegative number τ .

- The dual of the above modified OPF problem can be obtained from the Dual OPF by incorporating the extra constraint (19).
- If optimal τ becomes zero, then the OPF and modified OPF problems will have the same solution, meaning that the (k, l) entry of $T(x^{\text{opt}}, r^{\text{opt}})$ is non-positive.

Notice that the modified OPF problem defined above allows the reactive load at bus k to be over-satisfied, but enforces extra consumption of both active and reactive loads at buses k, l and reduces the maximum flow limit on line (k, l) . Therefore, it is very likely to obtain $\tau^{\text{opt}} = 0$ due to these penalties for load over-satisfaction (note that the imposed over-satisfaction of active load often leads to more power loss). The above modified OPF problem is defined to ensure the non-positivity of only the (k, l) entry of $T(x^{\text{opt}}, r^{\text{opt}})$. A similar modified OPF can be defined corresponding to all off-diagonal entries of $T(x^{\text{opt}}, r^{\text{opt}})$.

So far, the reason why the off-diagonal entries of $T(x^{\text{opt}}, r^{\text{opt}})$ are expected to be non-positive is investigated. Having assumed the presence of this sign structure on $T(x^{\text{opt}}, r^{\text{opt}})$, consider the matrix

$$\begin{bmatrix} T(x^{\text{opt}}, r^{\text{opt}}) & \bar{T}(x^{\text{opt}}, r^{\text{opt}}) \times \omega \\ -\bar{T}(x^{\text{opt}}, r^{\text{opt}}) \times \omega & T(x^{\text{opt}}, r^{\text{opt}}) \end{bmatrix} \quad (20)$$

for a given real number ω . As argued in the proof of Theorem 3, the smallest eigenvalue of the above matrix is repeated twice when $\omega = 0$. Hence, there exists an interval $[0, \omega^{\text{max}}]$ (where $\omega^{\text{max}} > 0$) such that the smallest eigenvalue of the matrix (20) is repeated twice for every ω belonging to this interval. Now, note that if $\omega^{\text{max}} > 1$, then the zero-duality-gap condition given in Theorem 2 is satisfied. This happens whenever $\bar{T}(x^{\text{opt}}, r^{\text{opt}})$ is sufficiently smaller than $T(x^{\text{opt}}, r^{\text{opt}})$ with respect to a suitable measure on their entries. As can be justified intuitively and verified in simulations, this is the case for practical systems operating at normal a condition, including the IEEE test systems.

It is noteworthy that Theorem 5 can be generalized to a general network (with arbitrary constraints) to deduce that there exists a large set for Y such that the ε -modified OPF problem has zero duality gap with respect to all network topologies Y in that region.

D. Power Loss Minimization

In this subsection, we consider the loss minimization problem, as an important special case of the OPF problem. This corresponds to the assumption $f_k(P_{G_k}) = P_{G_k}$ for every $k \in \mathcal{G}$. Most of the results to be presented here can be extended to a general OPF problem. With no loss of generality, assume that $\text{Re}\{Y\}$ has exactly one zero eigenvalue, implying that (i) the graph associated with the resistive part of the network

is strongly connected [32], and (ii) every load modeled as a shunt admittance has no resistive part. Notice that the power loss in a power system can be reduced by either increasing the voltage limits or decreasing the resistance of transmission lines. The next lemma investigates an ideal case where the power loss is zero.

Theorem 6: If the active power losses in the transmission lines were zero at optimality, then there would exist an optimal dual point $(x^{\text{opt}}, r^{\text{opt}})$ satisfying the relations

$$r^{\text{opt}} = 0, \quad \lambda_k^{\text{opt}} = 1, \quad \gamma_k^{\text{opt}} = \mu_k^{\text{opt}} = \lambda_{lm}^{\text{opt}} = \mu_{lm}^{\text{opt}} = 0$$

for every $k \in \mathcal{N}$ and $(l, m) \in \mathcal{L}$. Moreover, this dual solution satisfies the zero-duality-gap condition (ii) given in Theorem 2. *Proof:* Consider a specific point (x, r) defined as $r = 0$ and

$$\begin{aligned} \Delta_k &= \underline{\gamma}_k = \bar{\gamma}_k = \underline{\mu}_k = \bar{\mu}_k = \lambda_{lm} = \mu_{lm} = 0 \\ \bar{\lambda}_k &:= \begin{cases} 0 & \text{if } k \in \mathcal{G} \\ 1 & \text{otherwise} \end{cases} \end{aligned}$$

for all $k \in \mathcal{N}$ and $(l, m) \in \mathcal{L}$. It is straightforward to verify that $h(x, r) = \sum_{k \in \mathcal{N}} P_{D_k}$. On the other hand, since the OPF problem is feasible and the total power loss is zero, the optimal objective value of the OPF problem is equal to the total demand. This shows that the objective value of the Dual problem at (x, r) is identical to the optimal value of the OPF problem. Hence, to prove that (x, r) is a dual solution, it suffices to show that (x, r) is a feasible point of this optimization problem. To this end, it can be verified that

$$\lambda_k = 1, \quad \gamma_k = 0, \quad \mu_k = 0, \quad \forall k \in \mathcal{N}$$

and hence

$$A(x, r) = \begin{bmatrix} \text{Re}\{Y\} & 0 \\ 0 & \text{Re}\{Y\} \end{bmatrix}$$

Therefore, $A(x, r)$ is positive semidefinite and has a zero eigenvalue of multiplicity 2. This means that $(x^{\text{opt}}, r^{\text{opt}}) = (x, r)$ is indeed a maximizer of Optimization 4 for which the sufficient zero-duality-gap condition (ii) given in Theorem 2 holds. ■

Theorem 6 studies a special type of the OPF problem in an ideal case of no power loss, and presents an optimal dual solution explicitly from which it can be seen that the duality gap is zero. However, active power loss is nonzero, but small, in practice. In that case, if the Lagrange multipliers λ_k^{opt} , γ_k^{opt} and μ_k^{opt} are treated as nodal prices for active and reactive powers as well as voltage levels, it can be argued that the optimal point in a lossy case is likely to be close enough to the dual solution given in Theorem 6 so that the matrix $A(x^{\text{opt}}, r^{\text{opt}})$ will still have two zero eigenvalues. In other words, it is expected that a small power loss in the transmission lines does not create a nonzero duality gap.

V. POWER SYSTEM EXAMPLES

This section illustrates our results through two examples. Example 1 uses the IEEE benchmark systems archived at [22] to show the practicality of our result. Since the systems analyzed in Example 1 are so large that the specific values of the optimal solutions cannot be provided in the paper, some smaller examples are analyzed in Example 2 with more details.

The results of this section are attained using the following software tools:

- The MATLAB-based toolbox “YALMIP” (together with the solver “SEDUMI”) is used to solve the Dual OPF problem (i.e. Optimization 4), which is an SDP problem [29].
- The software toolbox “MATPOWER” is used to solve the OPF problem in Example 1 for the sake of comparison. The data for the IEEE benchmark systems analyzed in this example is extracted from the library of this toolbox [30].
- The software toolbox “PSAT” is used to draw and analyze the power networks given in Example 2 [31].

A. Example 1: IEEE Benchmark Systems

Consider the OPF problems associated with IEEE systems with 14, 30, 57, 118 and 300 buses, where

- There are constraints on the voltage magnitude, active power and reactive power at every bus as well as the apparent power at every line.
- The objective function is either the total generation cost or the power loss.

In simulations, we observed that the necessary and sufficient zero-duality-gap condition (i) given in Theorem 2 is always satisfied for all these systems. However, since the main algorithm proposed here is based on the sufficient zero-duality-gap condition (ii) delineated in Theorem 2, we studied this condition for IEEE systems and noticed that the condition is always satisfied after a small perturbation of Y , as discussed below. Due to space restrictions, the details will be provided only in one case: the loss minimization for the IEEE 30-bus system.

Consider the OPF problem for the IEEE 30-bus system, where the objective is to minimize the total power generated by the generators. When Optimization 4 is solved, the four smallest eigenvalues of the matrix

$$A(x^{\text{opt}}, r^{\text{opt}}) = \begin{bmatrix} T(x^{\text{opt}}, r^{\text{opt}}) & \bar{T}(x^{\text{opt}}, r^{\text{opt}}) \\ -\bar{T}(x^{\text{opt}}, r^{\text{opt}}) & T(x^{\text{opt}}, r^{\text{opt}}) \end{bmatrix}$$

would be obtained as 0, 0, 0, 0. Since the number of zero eigenvalues is 4, condition (ii) in Theorem 2 is violated. To explore the underlying reason, consider the circuit of this power system that is depicted in Figure 2. The circuit is composed of three regions connected to each other via some transformers. This implies that if each line of the circuit is replaced by its resistive part, the resulting resistive graph will not be connected (since the lines with transformers are assumed to have no resistive parts). Thus, the graph induced by $\text{Re}\{Y\}$ is not strongly connected. Although this does not create a nonzero duality gap, it causes our sufficient duality-gap condition to be violated (see Corollary 2). This is an issue with all the IEEE benchmark systems. This can be easily fixed by adding a little resistance to each transformer, say on the order of 10^{-5} (per unit). After this modification to the real part of Y , the four smallest eigenvalues of the matrix $A(x^{\text{opt}}, r^{\text{opt}})$ turn out to be 0, 0, 0.0053, 0.0053; i.e. the zero eigenvalues resulting from the non-connectivity of the resistive graph have

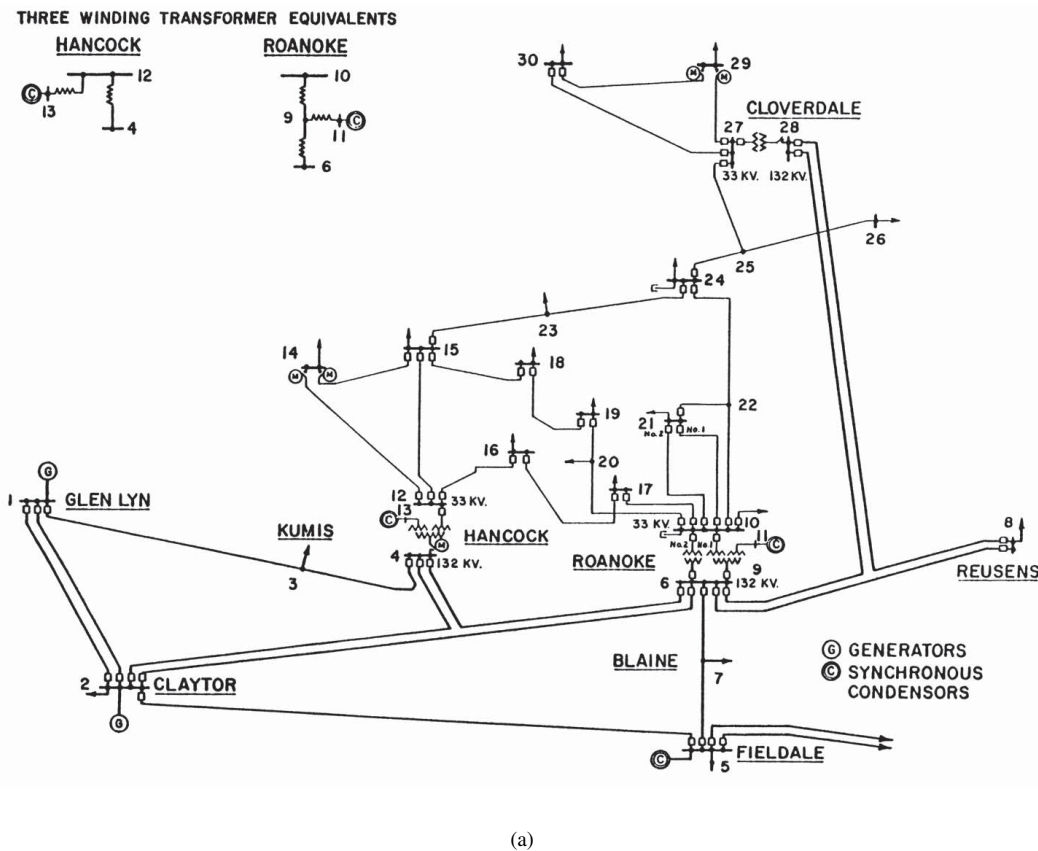

(a)

Fig. 2. The circuit of the IEEE 30-bus system taken from [22].

disappeared. Now, Condition (ii) in Theorem 2 is satisfied and therefore the vector of optimal voltages can be recovered using the algorithm described after Theorem 2.

To illustrate the discussions made in Section IV, we note that (for every $k \in \mathcal{N}$)

$$\begin{aligned} \lambda_k^{\text{opt}} &\in [1, 1.1466], & \gamma_k^{\text{opt}} &\in [-0.0062, 0.1443], \\ \mu_k^{\text{opt}} &\in [-0.0216, 0] \end{aligned}$$

Hence

- λ_k^{opt} 's are all positive and around 1.
- γ_k^{opt} 's are all but one nonnegative, and besides they are around 0.
- μ_k^{opt} 's are all very close to 0.

Moreover, the maximum absolute values of the entries of $\bar{T}(x^{\text{opt}}, r^{\text{opt}})$ is 0.1844, whereas the average absolute values of the nonzero entries of $T(x^{\text{opt}}, r^{\text{opt}})$ is 4.2583. This confirms the claim in Section IV-C that the matrix $\bar{T}(x^{\text{opt}}, r^{\text{opt}})$ is expected to be negligible compared to $T(x^{\text{opt}}, r^{\text{opt}})$.

The computation on the IEEE benchmark examples were all finished in a few seconds and the number of iterations for each example was between 5 and 20. Note that although Optimization 4 is convex and there is no convergence problem regardless of what initial point is used, the number of iterations needed to converge mainly depends on the choice of starting point. It is worth mentioning that when different algorithms implemented in Matpower were applied to these systems, some of the constraints are violated at the optimal point probably

due to the relatively large-scale and non-convex nature of the OPF problem. However, no constraint violation have occurred by solving the dual of the OPF problem due to its convexity.

B. Example 2: Small Systems

The IEEE test systems in the previous example operate in a normal condition at which the optimal bus voltages are close to each other in both magnitude and phase. This example illustrates that the sufficient zero-duality-gap condition (ii) given in Theorem 2 is satisfied even in the absence of such a normal operation. Consider three distributed power systems, referred to as Systems 1, 2 and 3, depicted in Figure 3. Note that Systems 2 and 3 are radial, while System 1 has a loop. The detailed specifications of these systems are provided in Table I in per unit for the voltage rating 400 kV and the power rating 100 MVA, in which \bar{z}_{lm} and \bar{y}_{lm} denote the series impedance and the shunt admittance of the Π model of the transmission line connecting buses $l, m \in \{1, 2, 3, 4\}$. The goal is to minimize the active power injected at slack bus 1 while satisfying the constraints given in Table II.

Optimization 4 is solved for each of these systems, and it is observed that the zero-duality-gap condition derived in this work always holds. A globally optimal solution of the OPF problem recovered from the solution of Optimization 4 is provided in Table III (P_{loss} and Q_{loss} in the table represent the total active and reactive power losses, respectively). It is interesting to note that although different buses have very

TABLE I
PARAMETERS OF THE SYSTEMS GIVEN IN FIGURE 3.

Parameters	System 1	System 2	System 3
\bar{z}_{12}	0.05 + 0.25i	0.1 + 0.5i	0.10 + 0.1i
\bar{z}_{13}	0.04 + 0.40i	None	None
\bar{z}_{23}	0.02 + 0.10i	0.02 + 0.20i	0.01 + 0.1i
\bar{z}_{14}	None	None	0.01 + 0.2i
\bar{y}_{12}	0.03i	0.01i	0.03i
\bar{y}_{13}	0.025i	None	None
\bar{y}_{23}	0.01i	0.01i	0.01i
\bar{y}_{14}	None	None	0.01i

TABLE II
CONSTRAINTS TO BE SATISFIED FOR THE SYSTEMS GIVEN IN FIGURE 3.

Constraints	System 1	System 2	System 3
$P_{D_2} + Q_{D_2}i$	0.95 + 0.4i	0.7 + 0.02i	0.9 + 0.02i
$P_{D_3} + Q_{D_3}i$	0.9 + 0.6i	0.65 + 0.02i	0.6 + 0.02i
$P_{D_4} + Q_{D_4}i$	None	None	0.9 + 0.02i
V_1^{\max}	1.05	1.4	1

disparate voltage magnitudes and phases, the duality gap is still zero. The optimal solution of Optimization 4 is summarized in Table IV to demonstrate that the Lagrange multipliers corresponding to active and reactive power constraints are positive.

As another scenario, let the desired voltage magnitude at the slack bus of System 1 be changed from 1.05 to 1. It can be verified that the optimal value of Optimization 4 becomes $+\infty$, which simply implies that the corresponding OPF problem is infeasible.

We repeated several hundred times this example by randomly choosing the parameters of the systems given in Figure 3 over a wide range of values. In all these trials, the algorithm prescribed in Section III always found a globally optimal solution of the OPF problem or detected its infeasibility.

TABLE III
PARAMETERS OF THE OPF PROBLEM RECOVERED FROM THE SOLUTION OF OPTIMIZATION 4.

Recovered Parameters	System 1	System 2	System 3
V_1^{opt}	1.05 \angle 0°	1.4 \angle 0°	1 \angle 0°
V_2^{opt}	0.71 \angle -20.11°	1.10 \angle -25.73°	0.78 \angle -10.58°
V_3^{opt}	0.68 \angle -21.94°	1.08 \angle -31.96°	0.76 \angle -16.31°
V_4^{opt}	None	None	0.95 \angle -10.82°
$P_{\text{loss}}^{\text{opt}}$	0.2193	0.1588	0.3877
$Q_{\text{loss}}^{\text{opt}}$	1.2944	0.7744	0.5343

TABLE IV
LAGRANGE MULTIPLIERS OBTAINED BY SOLVING OPTIMIZATION 4 FOR THE SYSTEMS GIVEN IN FIGURE 3.

Lagrange Multipliers	System 1	System 2	System 3
λ_2^{opt}	1.3809	1.4028	1.7176
λ_3^{opt}	1.4155	1.4917	1.7900
λ_4^{opt}	None	None	1.0207
γ_2^{opt}	0.4391	0.2508	0.1764
γ_3^{opt}	0.4955	0.2633	0.1858
γ_4^{opt}	None	None	0.0061
μ_1^{opt}	0.0005	0.0001	0.0005

VI. CONCLUSIONS

This paper is concerned with the optimal power flow (OPF) problem that has been studied for about half a century and is notorious for its high nonconvexity. We have derived the dual of a reformulated OPF problem as a convex (SDP) optimization, which can be solved efficiently in polynomial time. We have provided a necessary and sufficient condition under which the duality gap is zero and hence a globally optimal solution to the OPF problem can be recovered from a dual optimal solution. This condition is satisfied for the IEEE benchmark systems with 14, 30, 57, 118 and 300 buses. Since this condition is hard to study, a sufficient zero-duality-gap condition is also proposed. We justify why this sufficient condition might hold widely in practice. The main underlying reasons for zero duality gap are (i) the particular modeling of transmission lines and transformers, and (ii) the non-negativity of physical quantities such as resistance and inductance.

As expected and already reported in [19], local-search algorithms converge faster than SDP algorithms for solving an OPF problem. However, the SDP problem derived here can be useful for addressing many problems such as: (i) finding a globally optimal solution, (ii) verifying whether a locally optimal solution is globally optimal, (iii) solving emerging optimization problems in smart grids where the existing local-search algorithms may not work well [35], and (iv) identifying the number of solutions of a power flow problem. Note that the current SDP solvers cannot handle OPF problems with several thousand buses efficiently. However, the authors have observed that those SDP problems can be reduced to second-order-cone programs, which can be solved in less than a minute for OPF problems with as many as 10,000 buses. The details of this result and some other by-products of the convexification of the OPF problem are currently under study.

ACKNOWLEDGMENT

The authors would like to gratefully acknowledge John C. Doyle for fruitful discussions on this topic. This research was supported by ONR MURI N00014-08-1-0747 ‘‘Scalable, Data-driven, and Provably-correct Analysis of Networks,’’ ARO MURI W911NF-08-1-0233 ‘‘Tools for the Analysis and Design of Complex Multi-Scale Networks,’’ the Army’s W911NF-09-D-0001 Institute for Collaborative Biotechnology, and NSF NetSE grant CNS-0911041.

APPENDIX

A. LMI and SDP Optimization Problems

The area of convex optimization has seen remarkable progress in the past two decades, particularly in linear matrix inequalities (LMIs) and semidefinite programming (SDP) where the goal is to minimize a linear function subject to some LMIs [21], [23]. The book [24] describes several difficult control problems that can be cast as LMI/SDP problems. The recent advances in this field have been successfully applied to different problems in other areas, e.g. circuit and communications [25], [26]. A powerful property in semidefinite programming is that the dual of an SDP optimization problem

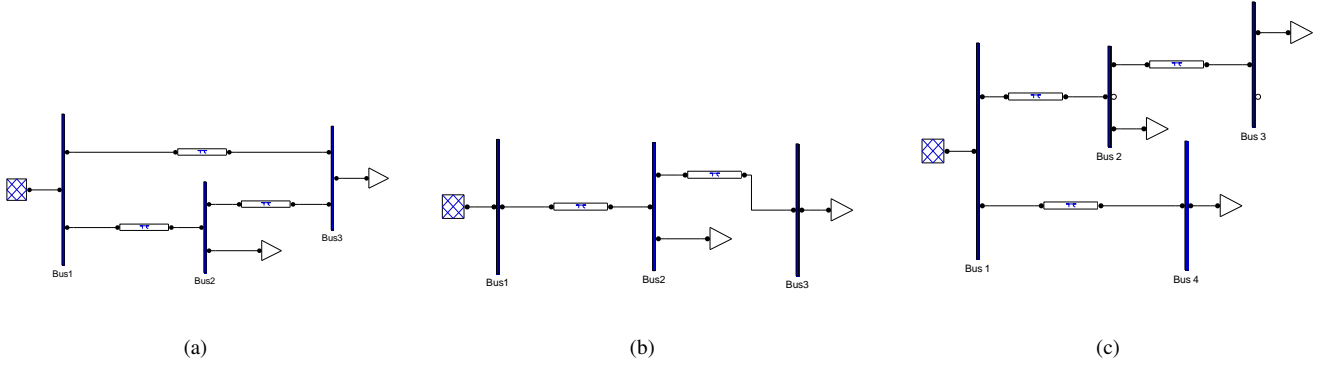

Fig. 3. Figures (a), (b) and (c) depict Systems 1, 2 and 3 studied in Example 2, respectively.

is again an SDP problem and, moreover, strong duality often holds [23].

Given the scalar variables x_1, \dots, x_n , consider the problem of minimizing

$$a_1x_1 + a_2x_2 + \dots + a_nx_n \quad (21)$$

subject to the LMI constraint

$$A_0 + A_1x_1 + \dots + A_nx_n \preceq 0 \quad (22)$$

where a_1, \dots, a_n are given real numbers and A_0, \dots, A_n are given symmetric matrices in $\mathbf{R}^{n_0 \times n_0}$, for some natural number n_0 . Notice that the objective of the above optimization problem is a linear scalar function, and its constraint is an LMI. The above optimization problem is referred to as *an SDP problem*, which belongs to the category of convex optimization problems that can be solved efficiently. To write the Lagrangian for the above optimization problem, a Lagrange multiplier should be introduced for the inequality (22). In light of the generalized Lagrangian theory, the multiplier associated with the inequality (22) is a symmetric matrix W in $\mathbf{R}^{n_0 \times n_0}$ that must be positive semidefinite. The corresponding Lagrangian will be as follows:

$$\sum_{k=1}^n a_k x_k + \text{Tr} \left\{ W \left(A_0 + \sum_{k=1}^n A_k x_k \right) \right\}$$

Note that the trace operator performs the multiplication between the expression in the constraint (22) and its associated Lagrange multiplier. Minimizing the above Lagrangian over x_1, \dots, x_n and then maximizing the resulting term over $W \succeq 0$ lead to the optimization problem of maximizing

$$\text{Tr}\{W A_0\}$$

subject to the constraints

$$\text{Tr}\{W A_k\} + a_k = 0, \quad k = 1, 2, \dots, n$$

for a symmetric matrix variable $W \succeq 0$. This optimization problem is the dual of the initial optimization problem formulated in (21) and (22). If some mild conditions (such as Slater's conditions) hold, then the duality gap between the solutions of these two optimization problems becomes zero, meaning that the optimal objective values obtained by these problems will be identical. In this case, it is said that "strong duality"

holds; otherwise, only "weak duality" holds in which case the optimal value of the dual problem is only a lower bound on the optimal value of the original problem. One can refer to [21] and [23] for detailed discussions on LMI and SDP problems.

B. NP-Hardness of OPF Problems

Consider two extremely special (artificial) instances of the OPF problem in the sequel:

- **Case 1:** This case corresponds to the situation where $\mathcal{G} = \mathcal{N}$ and

$$\begin{aligned} f_k(P_{G_k}) &= P_{G_k}, & \forall k \in \mathcal{G} \\ V_k^{\min} &= V_k^{\max} = 1, & \forall k \in \mathcal{N} \\ P_k^{\min} &= Q_k^{\min} = -\infty, & \forall k \in \mathcal{G} \\ P_k^{\max} &= Q_k^{\max} = +\infty, & \forall k \in \mathcal{G} \\ S_{lm}^{\max} &= P_{lm}^{\max} = \Delta V_{lm}^{\max} = \infty, & \forall (l, m) \in \mathcal{L} \end{aligned}$$

The above setting makes the power balance equations together with the constraints (1a), (1b), (1d), (1e) and (1f) all disappear. It is straightforward to verify that the OPF problem reduces to

$$\begin{aligned} \min_{\mathbf{V}} & \left(\text{Re}\{\mathbf{V}^* Y \mathbf{V}\} + \sum_{k \in \mathcal{N}} P_{D_k} \right) \\ \text{s.t.} & \quad |V_k| = 1, \quad \forall k \in \mathcal{N} \end{aligned} \quad (23)$$

Note that if the lower limit P_k^{\min} chosen as $-\infty$ is not allowed to be less than zero, one can choose P_{D_k} sufficiently large so that the OPF problem again turns into the above optimization problem. Observe that the feasibility region of this OPF problem in the space of \mathbf{V} is a connected, but nonconvex, set (the nonconvexity comes from the fact that this region encloses the origin but does not contain it).

- **Case 2:** This case is obtained from Case 1 by including the extra assumption $\text{Im}\{Y\} = 0$ and changing the limits $Q_k^{\min} = -\infty$ and $Q_k^{\max} = +\infty$ to $Q_k^{\min} = Q_k^{\max} = 0$ for every $k \in \mathcal{G}$. With no loss of generality, suppose that the voltage angle at bus 1 is equal to 0. Then, the OPF problem can be written as

$$\begin{aligned} \min_{\mathbf{V}} & \left(\mathbf{V}^* Y \mathbf{V} + \sum_{k \in \mathcal{N}} P_{D_k} \right) \\ \text{s.t.} & \quad V_k \in \{-1, 1\}, \quad \forall k \in \mathcal{N} \end{aligned} \quad (24)$$

The feasibility region of this problem is a discrete set with an exponential number of points in terms of n .

The optimization problems given in (23) and (24) are both NP-hard [33]. Hence, the OPF problem is NP-hard as well, due to its special (artificial) Cases 1 and 2 being NP-hard. Note that although the NP-hardness of the OPF problem was proved here by focusing on the voltage constraints, one can come to the same conclusion by only considering the active or reactive constraints. Indeed, Lemma 1 presented earlier in this work shows that these constraints introduce indefinite quadratic constraints, which again make the OPF problem NP-hard [33].

C. Proofs

In this subsection, we prove Lemmas 1-2, Theorems 1-2 and Corollary 1.

Proof of Lemma 1: In order to prove (2a), one can write:

$$\begin{aligned} P_{k,\text{inj}} &= \text{Re}\{V_k I_k^*\} = \text{Re}\{\mathbf{V}^* e_k e_k^* \mathbf{I}\} = \text{Re}\{\mathbf{V}^* Y_k \mathbf{V}\} \\ &= \mathbf{X}^T \begin{bmatrix} \text{Re}\{Y_k\} & -\text{Im}\{Y_k\} \\ \text{Im}\{Y_k\} & \text{Re}\{Y_k\} \end{bmatrix} \mathbf{X} \\ &= \frac{1}{2} \mathbf{X}^T \begin{bmatrix} \text{Re}\{Y_k + Y_k^T\} & \text{Im}\{Y_k^T - Y_k\} \\ \text{Im}\{Y_k - Y_k^T\} & \text{Re}\{Y_k + Y_k^T\} \end{bmatrix} \mathbf{X} \\ &= \mathbf{X}^T \mathbf{Y}_k \mathbf{X} = \text{Tr}\{\mathbf{Y}_k \mathbf{X} \mathbf{X}^T\} \end{aligned}$$

The inequality (2b) can be derived similarly. On the other hand, the technique used above can be exploited to show that

$$\begin{aligned} S_{lm}^* &= V_l^* (V_l \bar{y}_{lm}) + V_l^* (V_l - V_m) y_{lm} = \mathbf{V} Y_{lm} \mathbf{V}^* \\ &= \text{Tr}\{\mathbf{Y}_{lm} \mathbf{X} \mathbf{X}^T\} - \text{Tr}\{\bar{\mathbf{Y}}_{lm} \mathbf{X} \mathbf{X}^T\} \end{aligned}$$

Inequalities (2c) and (2d) follow immediately from the above equality. The remaining inequalities in (2) can be proved similarly. ■

Proof of Lemma 2: Assume that W^{opt} is a rank-one solution of Optimization 3. Write this matrix as $\mathbf{X}^{\text{opt}}(\mathbf{X}^{\text{opt}})^T$ for some vector \mathbf{X}^{opt} , and define $\mathbf{X}_1^{\text{opt}}$ and $\mathbf{X}_2^{\text{opt}}$ in such a way that $\mathbf{X}^{\text{opt}} = \begin{bmatrix} (\mathbf{X}_1^{\text{opt}})^T & (\mathbf{X}_2^{\text{opt}})^T \end{bmatrix}^T$. It can be verified that the matrix

$$\begin{aligned} &\frac{1}{2} \mathbf{X}^{\text{opt}}(\mathbf{X}^{\text{opt}})^T \\ &+ \frac{1}{2} \begin{bmatrix} \mathbf{X}_1^{\text{opt}} \omega_1 - \mathbf{X}_2^{\text{opt}} \omega_2 \\ \mathbf{X}_1^{\text{opt}} \omega_2 + \mathbf{X}_2^{\text{opt}} \omega_1 \end{bmatrix} \begin{bmatrix} \mathbf{X}_1^{\text{opt}} \omega_1 - \mathbf{X}_2^{\text{opt}} \omega_2 \\ \mathbf{X}_1^{\text{opt}} \omega_2 + \mathbf{X}_2^{\text{opt}} \omega_1 \end{bmatrix}^T \end{aligned}$$

is a solution of Optimization 3 for every real numbers ω_1 and ω_2 such that $\omega_1^2 + \omega_2^2 = 1$. The proof is completed by noting that the above matrix has rank 2 for generic values of (ω_1, ω_2) . ■

Proof of Part (i) of Theorem 1: Consider the Lagrange multipliers introduced before Optimization 4 with the only difference that the multiplier

$$\begin{bmatrix} 1 & r_k^1 \\ r_k^1 & r_k^2 \end{bmatrix}$$

given in (7) should be replaced by a general matrix

$$\begin{bmatrix} r_k^0 & r_k^1 \\ r_k^1 & r_k^2 \end{bmatrix}$$

(indeed, we do not yet know that $r_k^0 = 1$.) The Lagrangian for Optimization 1 can be written as (after some simplifications)

$$\text{Tr}\{A(x, r) \mathbf{X} \mathbf{X}^T\} + h(x, r) + \sum_{k \in \mathcal{G}} (1 - r_k^0) \alpha_k$$

To obtain the dual of Optimization 1, the Lagrangian should first be minimized over \mathbf{X} and α_k 's, and then be maximized over the Lagrange multipliers. Observe that

- The minimum of $(1 - r_k^0) \alpha_k$ over the variable α_k is $-\infty$ unless $r_k^0 = 1$, in which case the minimum is zero.
- The minimum of the term

$$\text{Tr}\{A(x, r) \mathbf{X} \mathbf{X}^T\}$$

over \mathbf{X} is $-\infty$ unless $A(x, r)$ is positive semidefinite, in which case the minimum is zero.

The proof follows immediately from these observations. ■

Proof of Part (ii) of Theorem 1: One can derive the dual of Optimization 3 by means of the standard procedure outlined in Appendix A (see [21] and [24] for more details). This leads to Optimization 4, where its variable W plays the role of the Lagrange multiplier for the matrix constraint (8a) in Optimization 3. The details are omitted for brevity. In what follows, we will show that strong duality holds between Optimizations 3 and 4. Since these optimizations are both semidefinite programs and hence convex, it suffices to prove that Optimization 4 has a finite optimal objective value and a strictly feasible point (Slater's condition). Since the OPF problem is feasible and equivalent to Optimization 1, Optimization 1 has a finite optimal value. Optimization 4 is its dual by Part (i) of Theorem 1, and is therefore upper bounded by the finite optimal value of Optimization 1 (weak duality). To show that Optimization 4 has a strictly feasible point, consider the point (x, r) given below

$$\begin{aligned} \lambda_k &= \begin{cases} c_{k1} + 1 & \text{if } k \in \mathcal{G} \\ 1 & \text{otherwise} \end{cases}, \quad \bar{\lambda}_k = 1, \quad \lambda_{lm} = \varepsilon \\ \gamma_k &= \bar{\gamma}_k = 1, \\ \mu_k &= 1, \quad \bar{\mu}_k = 2, \quad \mu_{lm} = 1, \\ r_k^1 &= 0, \quad r_k^2 = 1, \\ r_{lm}^1 &= r_{lm}^4 = r_{lm}^6 = 1, \quad r_{lm}^2 = r_{lm}^3 = r_{lm}^5 = 0 \end{aligned} \tag{25}$$

for $k \in \mathcal{N}$ and $(l, m) \in \mathcal{L}$, where ε is some positive number. Then $\lambda_k = \gamma_k = 0$ and $\mu_k = 1$. Now, observe that

- The variable x whose entries are specified in (25) is strictly positive componentwise.
- The relations

$$\begin{aligned} &\begin{bmatrix} r_{lm}^1 & r_{lm}^2 & r_{lm}^3 \\ r_{lm}^2 & r_{lm}^4 & r_{lm}^5 \\ r_{lm}^3 & r_{lm}^5 & r_{lm}^6 \end{bmatrix} = I \succ 0 \\ &\begin{bmatrix} 1 & r_{l1} \\ r_{l11} & r_{l2} \end{bmatrix} = I \succ 0 \end{aligned}$$

hold.

- We have

$$h(x, r) = I + \varepsilon \sum_{(l,m) \in \mathcal{L}} \mathbf{Y}_{lm} + \sum_{(l,m) \in \mathcal{L}} M_{lm}$$

Since M_{lm} is positive semidefinite, $h(x, r)$ becomes strictly positive definite for sufficiently small values of ε . In light of the above observations, (x, r) given in (25) is a strictly feasible point of Optimization 4 for an appropriate value of ε . Hence, strong duality holds. ■

Proof of Part (i) of Theorem 2: Recall that the following properties hold for Optimizations 1–4:

- The optimal (objective) values of Optimizations 1 and 2 are the same, due to the equivalence between these optimizations.
- The optimal values of Optimizations 3 and 4 are identical, due to strong duality.

These properties yield that the duality gap for Optimization 1 is equal to the difference between the optimal values of Optimizations 2 and 3. The proof is completed by noting that this difference is zero if and only if Optimization 3 has a rank-one solution.

Proof of Part (ii) of Theorem 2: Let W^{opt} denote a solution of Optimization 3. It follows from Part (ii) of Theorem 1 and the KKT conditions that

$$\text{Tr} \{ A(x^{\text{opt}}, r^{\text{opt}}) W^{\text{opt}} \} = 0 \quad (26)$$

Denote the nonzero eigenvalues of W^{opt} as ρ_1, \dots, ρ_f and their associated unit eigenvectors as E_1, \dots, E_f for some nonnegative integer f . By writing W^{opt} as $\sum_{l=1}^f \rho_l E_l E_l^T$, it can be concluded from (26) and the positive semi-definiteness of W^{opt} and $A(x^{\text{opt}}, r^{\text{opt}})$ that

$$A(x^{\text{opt}}, r^{\text{opt}}) E_l = 0, \quad \forall l \in \{1, \dots, f\}$$

This implies that the orthogonal eigenvectors E_1, \dots, E_f all belong to the null space of $A(x^{\text{opt}}, r^{\text{opt}})$, which has dimension 2. Hence, f is less than or equal to 2. On the other hand, if $f = 1$, then Optimization 3 has a rank-one solution and consequently the duality gap is zero for Optimization 1 (see Part (i) of Theorem 2). Therefore, assume that f is equal to 2. It can be shown that there exist two matrices $T(x, r)$ and $\bar{T}(x, r)$ such that

$$A(x, r) = \begin{bmatrix} T(x, r) & \bar{T}(x, r) \\ -\bar{T}(x, r) & T(x, r) \end{bmatrix} \quad (27)$$

Decompose E_1 as $\begin{bmatrix} E_{11}^T & E_{12}^T \end{bmatrix}^T$ for some vectors $E_{11}, E_{12} \in \mathbf{R}^n$. It can be inferred from the above equation that $\begin{bmatrix} -E_{12}^T & E_{11}^T \end{bmatrix}^T$ is in the null space of $A(x^{\text{opt}}, r^{\text{opt}})$ as well. Since this vector is orthogonal to E_1 , the vector E_2 must be equal to $\pm \begin{bmatrix} -E_{12}^T & E_{11}^T \end{bmatrix}^T$. Thus, one can write

$$W^{\text{opt}} = \rho_1 \begin{bmatrix} E_{11} \\ E_{12} \end{bmatrix} \begin{bmatrix} E_{11}^T & E_{12}^T \end{bmatrix} + \rho_2 \begin{bmatrix} -E_{12} \\ E_{11} \end{bmatrix} \begin{bmatrix} -E_{12}^T & E_{11}^T \end{bmatrix} \quad (28)$$

Consider now the rank-one matrix

$$(\rho_1 + \rho_2) \begin{bmatrix} E_{11} \\ E_{12} \end{bmatrix} \begin{bmatrix} E_{11}^T & E_{12}^T \end{bmatrix} \quad (29)$$

Since W^{opt} given in (28) satisfies the constraints of Optimization 3 and also maximizes its objective function, it is easy to verify that the rank-one matrix in (29) is also a solution of

Optimization 3. In other words, Optimization 3 has a rank-one solution, which makes the duality gap for Optimization 1 equal to zero (in light of Part (i) of Theorem 2). ■

Proof of Corollary 1: As can be deduced from the proof of Part (ii) of Theorem 2, since $\begin{bmatrix} X_1^T & X_2^T \end{bmatrix}^T$ belongs to the null space of $A(x^{\text{opt}}, r^{\text{opt}})$, the vector $\begin{bmatrix} X_2^T & -X_1^T \end{bmatrix}^T$ is also in the null space of the same matrix. Now, recall that Optimization 3 has a rank-one solution W^{opt} that is decomposable as $\mathbf{X}^{\text{opt}}(\mathbf{X}^{\text{opt}})^T$, where \mathbf{X}^{opt} is a solution of Optimization 1. In light of the relation (26), \mathbf{X}^{opt} belongs to the null space of $A(x^{\text{opt}}, r^{\text{opt}})$ and hence there exist two real numbers ζ_1 and ζ_2 such that

$$\mathbf{X}^{\text{opt}} = \zeta_1 \begin{bmatrix} X_1 \\ X_2 \end{bmatrix} + \zeta_2 \begin{bmatrix} -X_2 \\ X_1 \end{bmatrix}$$

or equivalently

$$\mathbf{V}^{\text{opt}} = (\zeta_1 + \zeta_2 i)(X_1 + X_2 i)$$

This completes the proof of Part (i) of Corollary 1. Part (ii) of this corollary follows immediately from the proof of Part (ii) of Theorem 2. The details are omitted for brevity. ■

REFERENCES

- [1] J. A. Momoh, "Electric power system applications of optimization," *Markel Dekker*, New York, USA, 2001.
- [2] J. Carpentier, "Contribution to the economic dispatch problem," *Bulletin Society Francaise Electriciens*, vol. 3, no. 8, pp. 431-447, 1962.
- [3] M. Huneault and F. D. Galiana, "A survey of the optimal power flow literature," *IEEE Transactions on Power Systems*, vol. 6, no. 2, pp. 762-770, 1991.
- [4] G. L. Torres and V. H. Quintana, "Optimal power flow by a nonlinear complementarity method," *IEEE Transactions on Power Systems*, vol. 15, no. 3, pp. 1028-1033, 2000.
- [5] H. Wang, C. E. Murillo-Sanchez, R. D. Zimmerman, and R. J. Thomas, "On computational issues of market-based optimal power flow," *IEEE Transactions on Power Systems*, vol. 22, no. 3, pp. 1185-1193, 2007.
- [6] J. A. Momoh M. E. El-Hawary, and R. Adapa, "A review of selected optimal power flow literature to 1993. Part I: Nonlinear and quadratic programming approaches," *IEEE Transactions on Power Systems*, vol. 14, no. 1, pp. 96-104, 1999.
- [7] J. A. Momoh M. E. El-Hawary, and R. Adapa, "A review of selected optimal power flow literature to 1993. Part II: Newton, linear programming and interior point methods," *IEEE Transactions on Power Systems*, vol. 14, no. 1, pp. 105-111, 1999.
- [8] K. S. Pandya and S. K. Joshi, "A survey of optimal power flow methods," *Journal of Theoretical and Applied Information Technology*, vol. 4, no. 5, pp. 450-458, 2008.
- [9] H. Wei, H. Sasaki, J. Kubokawa, and R. Yokoyama, "An interior point nonlinear programming for optimal power flow problems with a novel data structure," *IEEE Transactions on Power Systems*, vol. 13, no. 3, pp. 870-877, 1998.
- [10] W. M. Lin, C. H. Huang, and T. S. Zhan, "A hybrid current-power optimal power flow technique," *IEEE Transactions on Power Systems*, vol. 23, no. 1, pp. 177-185, 2008.
- [11] Q. Y. Jiang, H. D. Chiang, C. X. Guo, and Y. J. Cao, "Power-current hybrid rectangular formulation for interior-point optimal power flow," *IET Generation, Transmission & Distribution*, vol. 3, no. 8, pp. 748-756, 2009.
- [12] Q. Jiang, G. Geng, C. Guo, and Y. Cao, "An efficient implementation of automatic differentiation in interior point optimal power flow," *IEEE Transactions on Power Systems*, vol. 25, no. 1, pp. 147-155, 2010.
- [13] R. A. Jabr, "Radial distribution load flow using conic programming," *IEEE Transactions on Power Systems*, vol. 21, no. 3, pp. 1458-1459, 2006.
- [14] R. A. Jabr, "Optimal power flow using an extended conic quadratic formulation," *IEEE Transactions on Power Systems*, vol. 23, no. 3, pp. 1000-1008, 2008.

- [15] D. Gan, R. J. Thomas, and R. D. Zimmerman, "Stability-constrained optimal power flow," *IEEE Transactions on Power Systems*, vol. 15, no. 2, pp. 535-540, 2000.
- [16] H. R. Cai, C. Y. Chung, and K. P. Wong, "Application of differential evolution algorithm for transient stability constrained optimal power flow," *IEEE Transactions on Power Systems*, vol. 23, no. 2, pp. 719-728, 2008.
- [17] K. Xie and Y. H. Song, "Dynamic optimal power flow by interior point methods," *IEE Proceedings - Generation, Transmission and Distribution*, vol. 148, no. 1, pp. 76-84, 2002.
- [18] Y. Xia and K. W. Chan, "Dynamic constrained optimal power flow using semi-infinite programming," *IEEE Transactions on Power Systems*, vol. 21, no. 3, pp. 1455-1457, 2006.
- [19] X. Bai, H. Wei, K. Fujisawa and Y. Wang, "Semidefinite programming for optimal power flow problems," *International Journal of Electric Power & Energy Systems*, vol. 30, no. 6-7, pp. 383-392, 2008.
- [20] J. Lavaei, A. Babakhani, A. Hajimiri and J. C. Doyle, "Solving Large-Scale Linear Circuit Problems via Convex Optimization," in *Proceedings of the 48th IEEE Conference on Decision and Control*, Shanghai, China, 2009.
- [21] S. Boyd and L. Vandenberghe, "Convex optimization," *Cambridge University Press*, 2004.
- [22] University of Washington, Power Systems Test Case Archive, <http://www.ee.washington.edu/research/pstca>.
- [23] E. De Klerk, "Aspects of semidefinite programming: interior point algorithms and selected applications," Applied Optimization Series, Vol. 65, *Kluwer Academic Publishers*, 2002.
- [24] S. Boyd, L. E. Ghaoui, E. Feron and V. Balakrishnan, "Linear matrix inequalities in system and control theory," *SIAM*, Philadelphia, PA, 1994.
- [25] L. Vandenberghe, S. Boyd and A. E. Gamal, "Optimizing dominant time constant in RC circuits," *IEEE Transactions on Computer-Aided Design of Integrated Circuits and Systems*, vol. 17, no. 2, pp. 110-125, 1998.
- [26] J. Lavaei, A. Babakhani, A. Hajimiri and J. C. Doyle, "Programmable antenna design using convex optimization," in *19th International Symposium on Mathematical Theory of Networks and Systems*, Budapest, Hungary, 2010.
- [27] B. Recht, M. Fazel and P. A. Parrilo, "Guaranteed minimum rank solutions to linear matrix equations via nuclear norm minimization," to appear in *SIAM Review* (available online at <http://pages.cs.wisc.edu/~brecht/publications.html>).
- [28] H. Wolkowitz, R. Saigal, and L. Vandenberghe, editors, "Handbook of semidefinite programming: theory, algorithms and applications," *Kluwer*, 2000.
- [29] J. Löfberg, "A toolbox for modeling and optimization in MATLAB," in *Proceedings of the CACSD Conference*, Taipei, Taiwan, 2004.
- [30] R. D. Zimmerman, C. E. Murillo-Sánchez, and R. J. Thomas, "MATPOWER's extensible optimal power flow architecture," *IEEE Power and Energy Society General Meeting*, 2009.
- [31] F. Milano, "An open source power system analysis toolbox," *IEEE Transactions on Power Systems*, vol. 20, no. 3, pp. 1199-1206, 2005.
- [32] C. Godsil and G. Royle, "Algebraic graph theory," *volume 207 of Graduate Texts in Mathematics*. Springer, 2001.
- [33] T. F. González, "Handbook of approximation algorithms and metaheuristics," *Chapman & Hall/CRC Computer & Information Science Series*, 2007.
- [34] R. A. Jabr, A. H. Coonick and B. J. Cory, "A primal-dual interior point method for optimal power flow dispatching," *IEEE Transactions on Power Systems*, vol. 17, no. 3, pp. 654-662, 2002.
- [35] J. Lavaei, "Zero duality gap for classical OPF problem convexifies fundamental nonlinear power problems," in *Proceedings of the 2011 American Control Conference*, 2011.



Javad Lavaei (SM'10) received the B.Sc. degree from Sharif University of Technology in 2003 and the M.A.Sc. degree from Concordia University in 2007, both in Electrical Engineering. He received the Ph.D. degree in Control and Dynamical Systems from California Institute of Technology in 2011. His research interests lie in the area of control theory and its applications in circuits, communications, networks, and energy systems.

Javad Lavaei has authored and co-authored more than 50 articles during his master's and PhD studies. He has won the *Milton and Francis Clauser Doctoral Prize* for the best campus-wide Ph.D. thesis at Caltech. He has also won many other awards including *F. A. Gerard Prize*, *Governor General of Canada's Gold Medal*, *Northeastern Association of Graduate Schools Master's Thesis Award*, *Postgraduate Scholarship of Natural Sciences and Engineering Research Council of Canada*, and *Silver Medal in the 1999 International Mathematical Olympiad*.

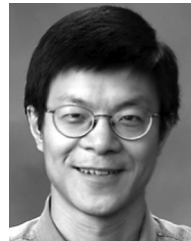

Steven H. Low (F'08) received the B.S. degree from Cornell University, Ithaca, NY, and the Ph.D. degree from the University of California, Berkeley, both in electrical engineering.

He is a Professor with the Computing & Mathematical Sciences and Electrical Engineering departments at California Institute of Technology, Pasadena, and hold guest faculty position with the Swinbourne University, Australia and Shanghai Jiaotong University, China. Prior to that, he was with AT&T Bell Laboratories, Murray Hill, NJ, and the University of Melbourne, Melbourne, Australia.

Prof. Low was a co-recipient of the IEEE Bennett Prize Paper Award in 1997 and the 1996 R&D 100 Award. He was a member of the Networking and Information Technology Technical Advisory Group for the US President's Council of Advisors on Science and Technology (PCAST) in 2006. He was on the Editorial Board of the IEEE/ACM TRANSACTIONS ON NETWORKING, IEEE Trans on Automatic Control, ACM Computing Surveys, and the Computer Networks Journal. He is currently on the editorial boards of Foundations and Trends in Networking and is a Senior Editor of the IEEE JOURNAL ON SELECTED AREAS IN COMMUNICATION.